

HYPER SUPRIME-CAM

SATOSHI MIYAZAKI
NATIONAL ASTRONOMICAL OBSERVATORY
OF JAPAN

2007/10/24
ROE-JSPS Workshop 2007



Subaru Telescope

NATIONAL ASTRONOMICAL OBSERVATORY OF JAPAN

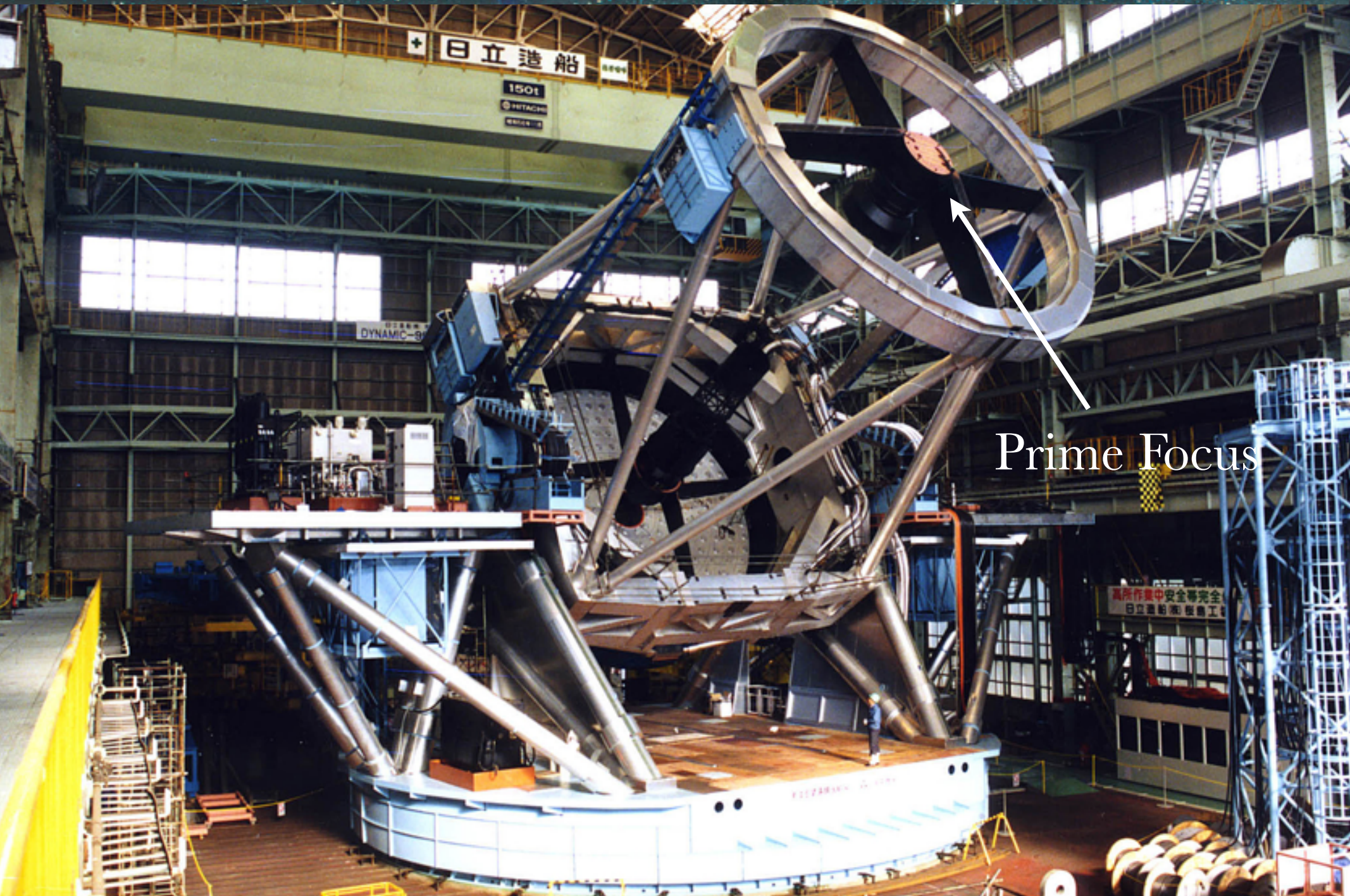

Prime Focus

SUBARU TELESCOPE

- One of thirteen 8-10 m class telescopes in the world (2007)
- Superb image quality (mostly natural seeing limit)
 - PM Actuators are controlled based on a static table.
 - Tracking is stable ($0''.1$ rms in 10 min blind tracking)
 - High Image quality wide field camera is realized.

No image stabilizer is
necessary

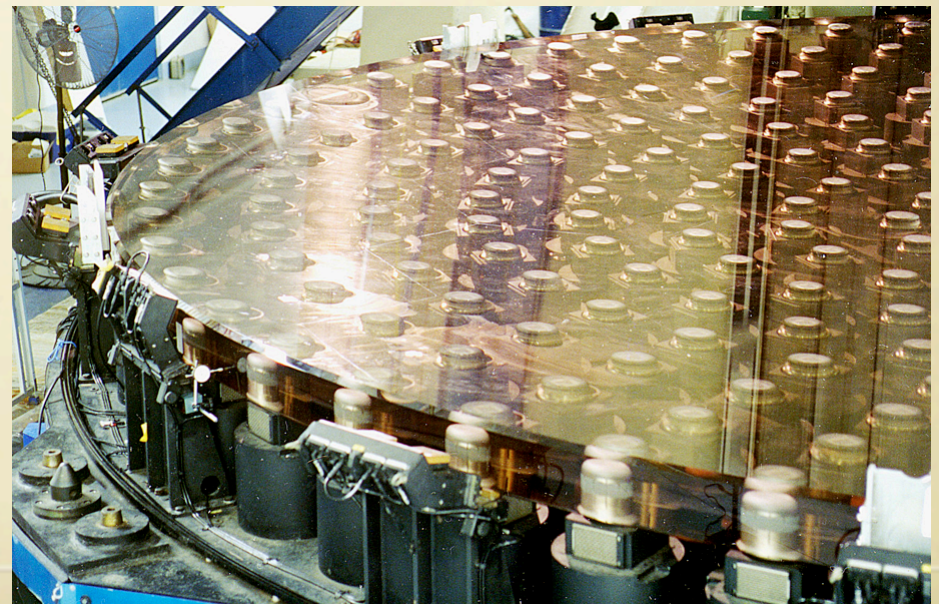

SUPRIME-CAM

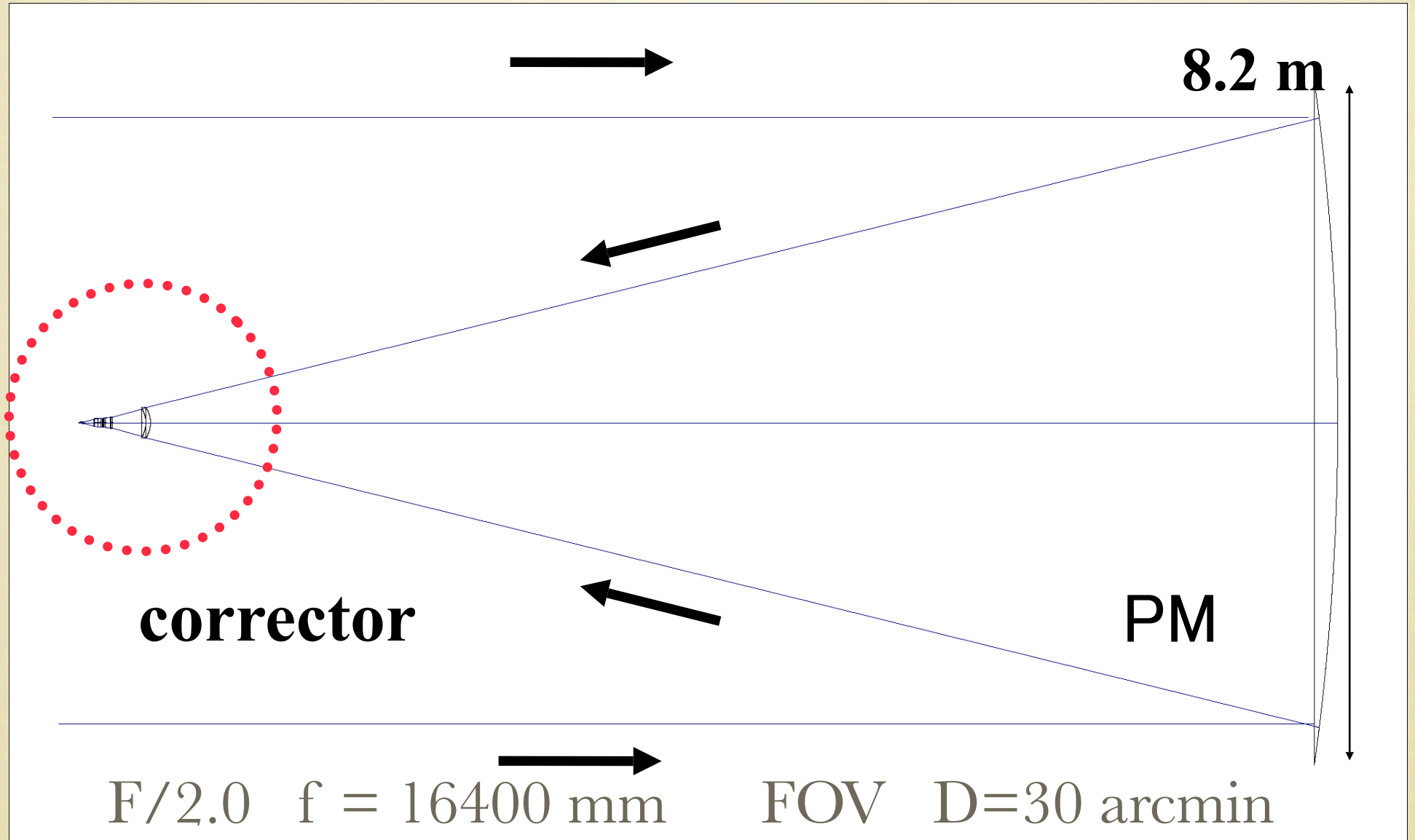

3D LAYOUT

SUPRIME CAM
FRI JUL 1 2005

SUBARU TELESCOPE
650 N AOHOKU PLACE
HILO HI 96720

TEST.ZMX
CONFIGURATION 1 OF 1

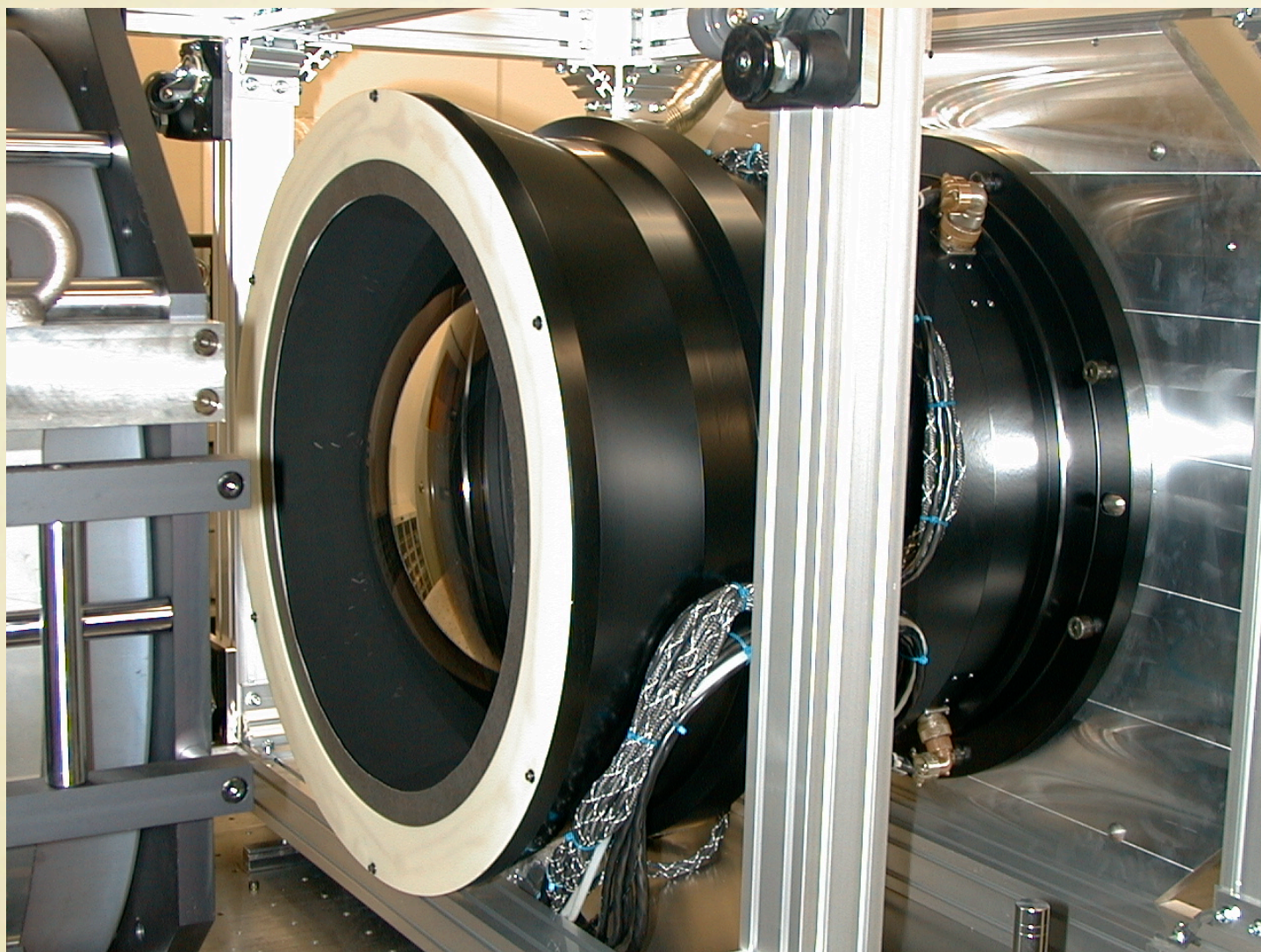

Canon G1 Phi 50 cm

Suprime-Cam CCD

MIT/LL CCID-20

800 Mpixel

6 cm (4096 pixel)

3 cm

(2048 pixel)

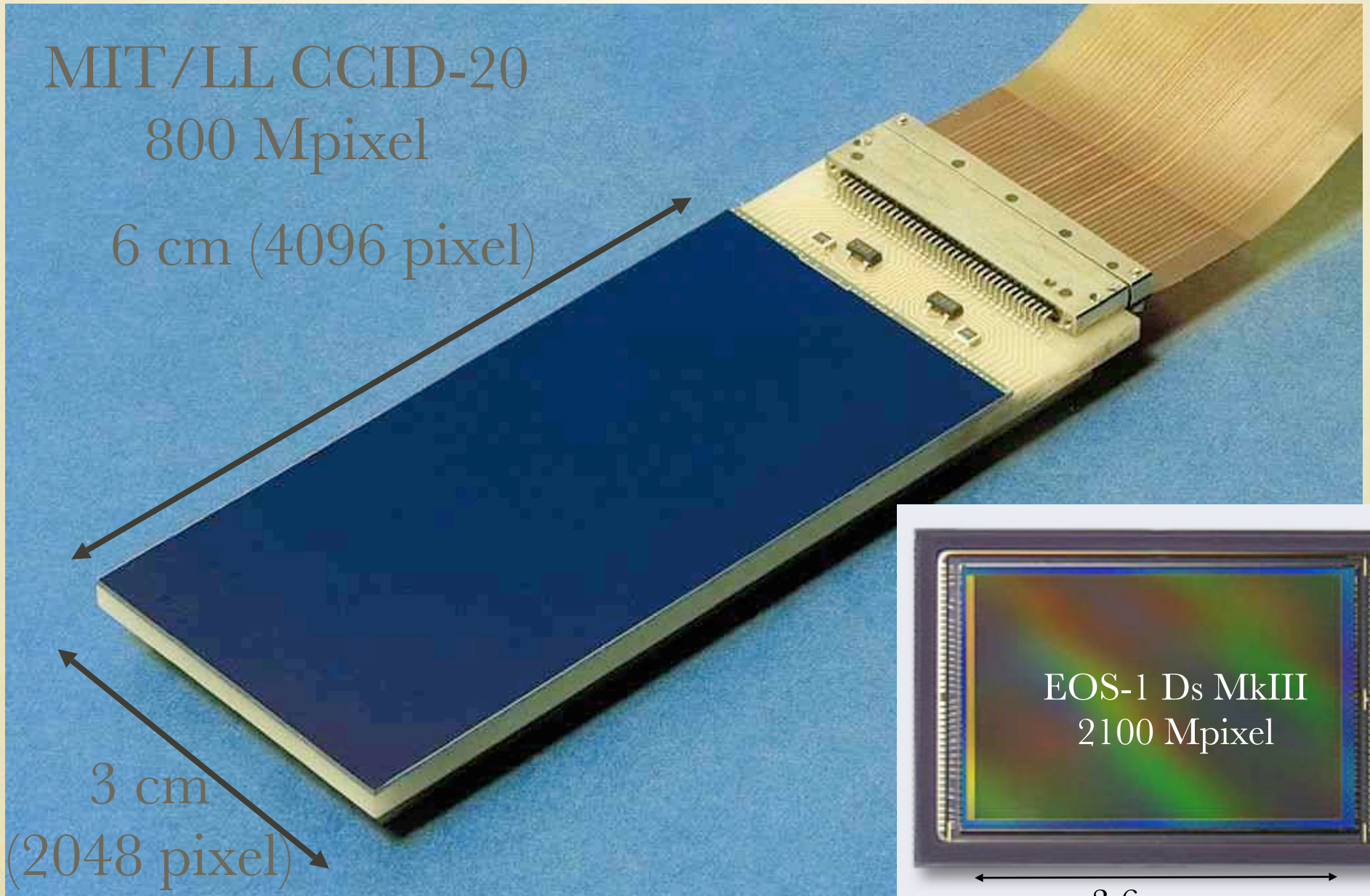

EOS-1 Ds MkIII

2100 Mpixel

3.6 cm

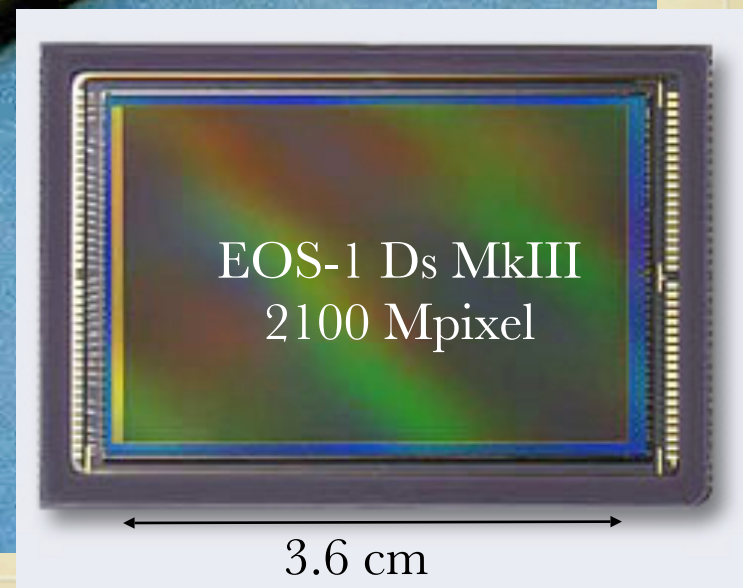

MIT LINCOLN LAB CCD

- One of X-ray CCD suppliers
 - ASCA, Chandra, Suzaku
- Low Noise, High CTE, Thick depletion layer (~ 40 micron)
- Optical CCD was supplied for astronomy communities through University of Hawaii

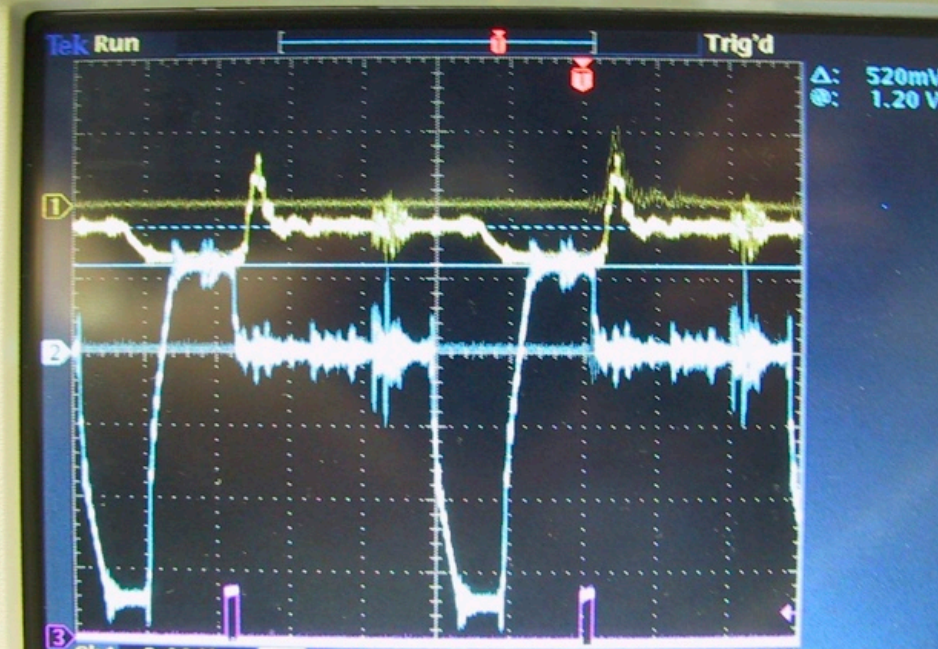

Alignment Pins

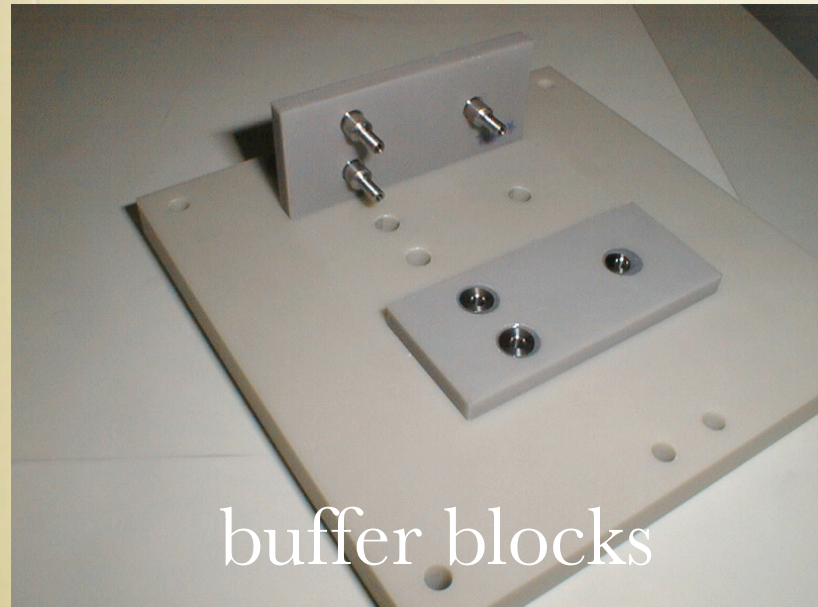
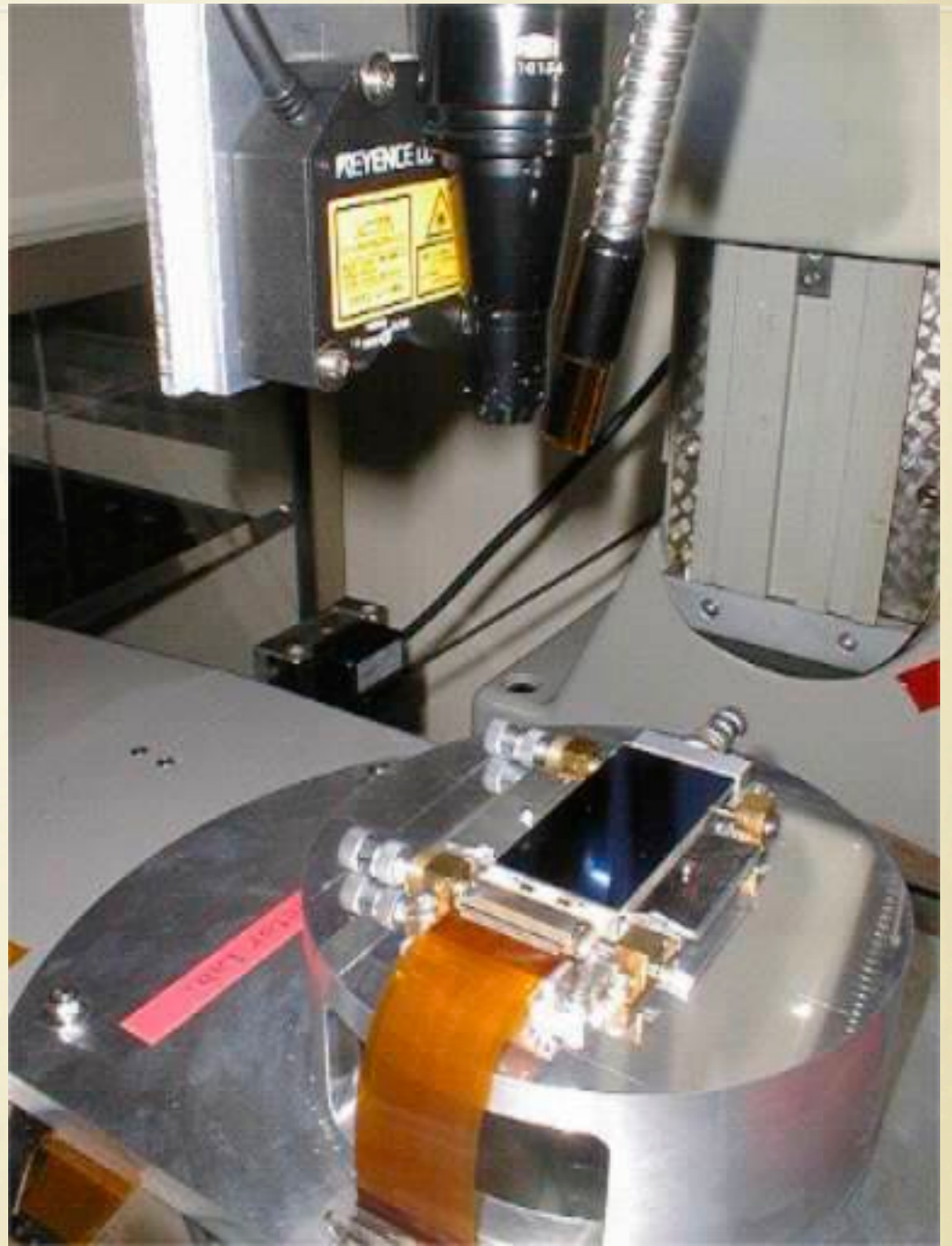
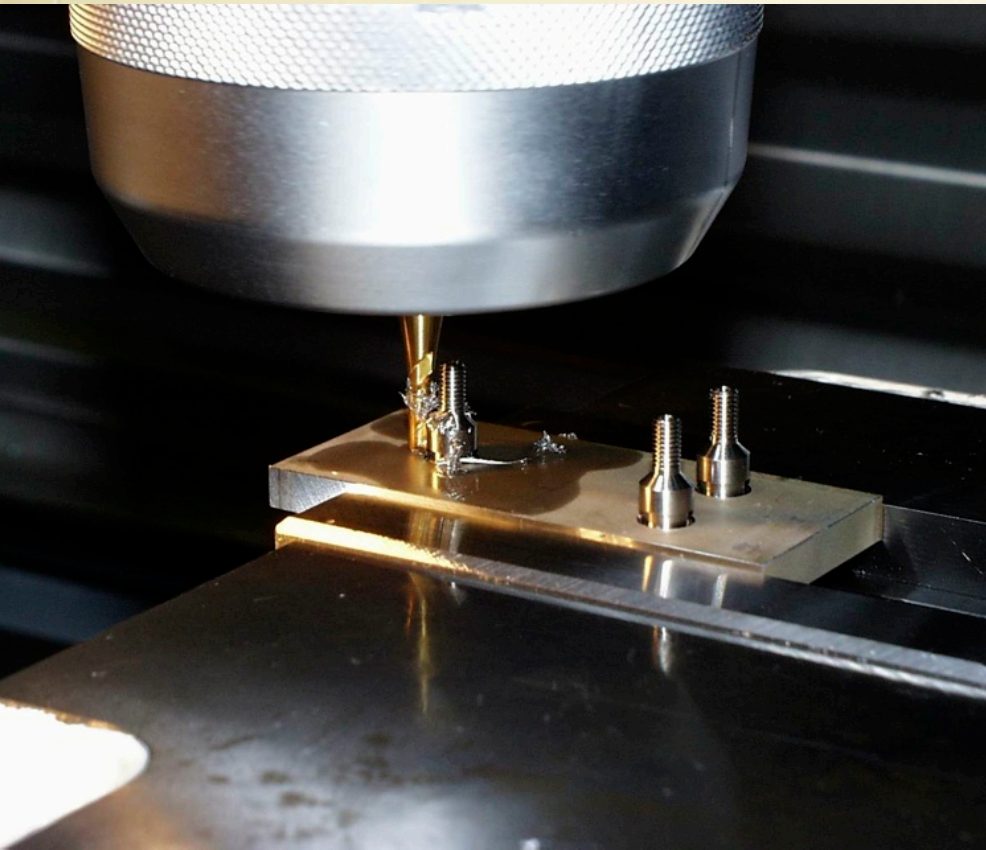

buffer blocks

Epoxy buffer block

Placement into the dewar

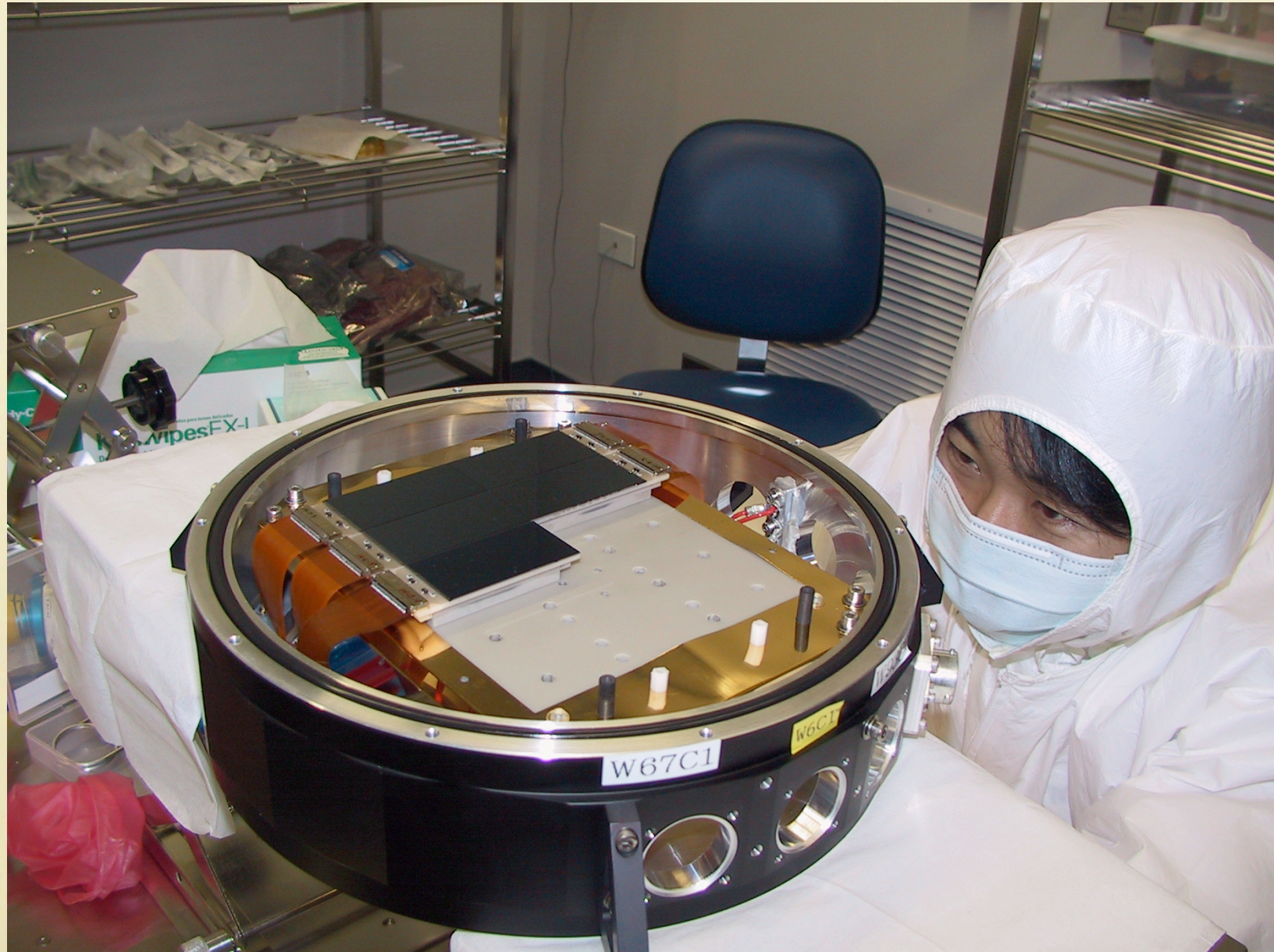

12 cm

15 cm

Focal depth \pm 30 micron

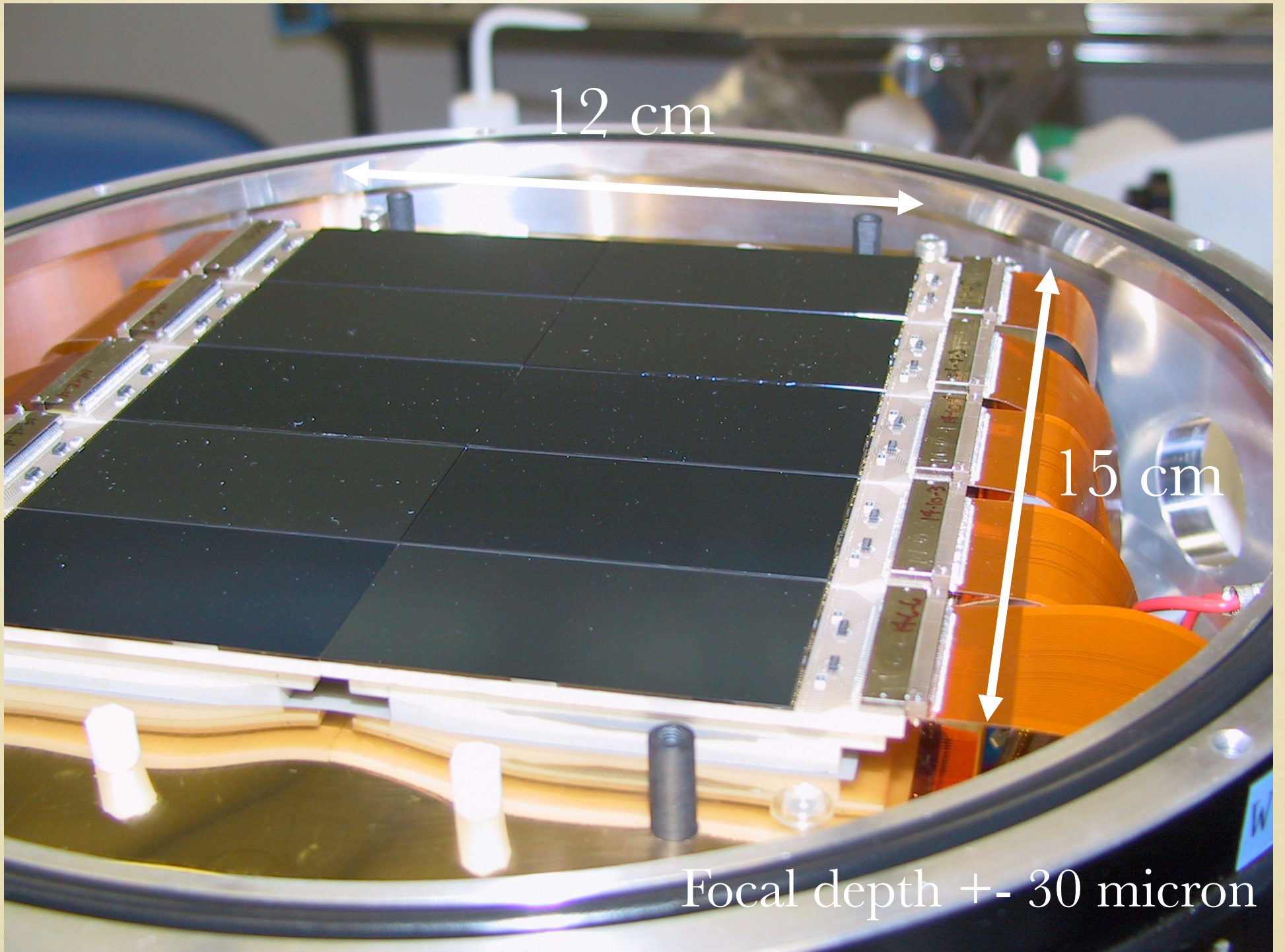

Suprime-Cam冷却デユワー

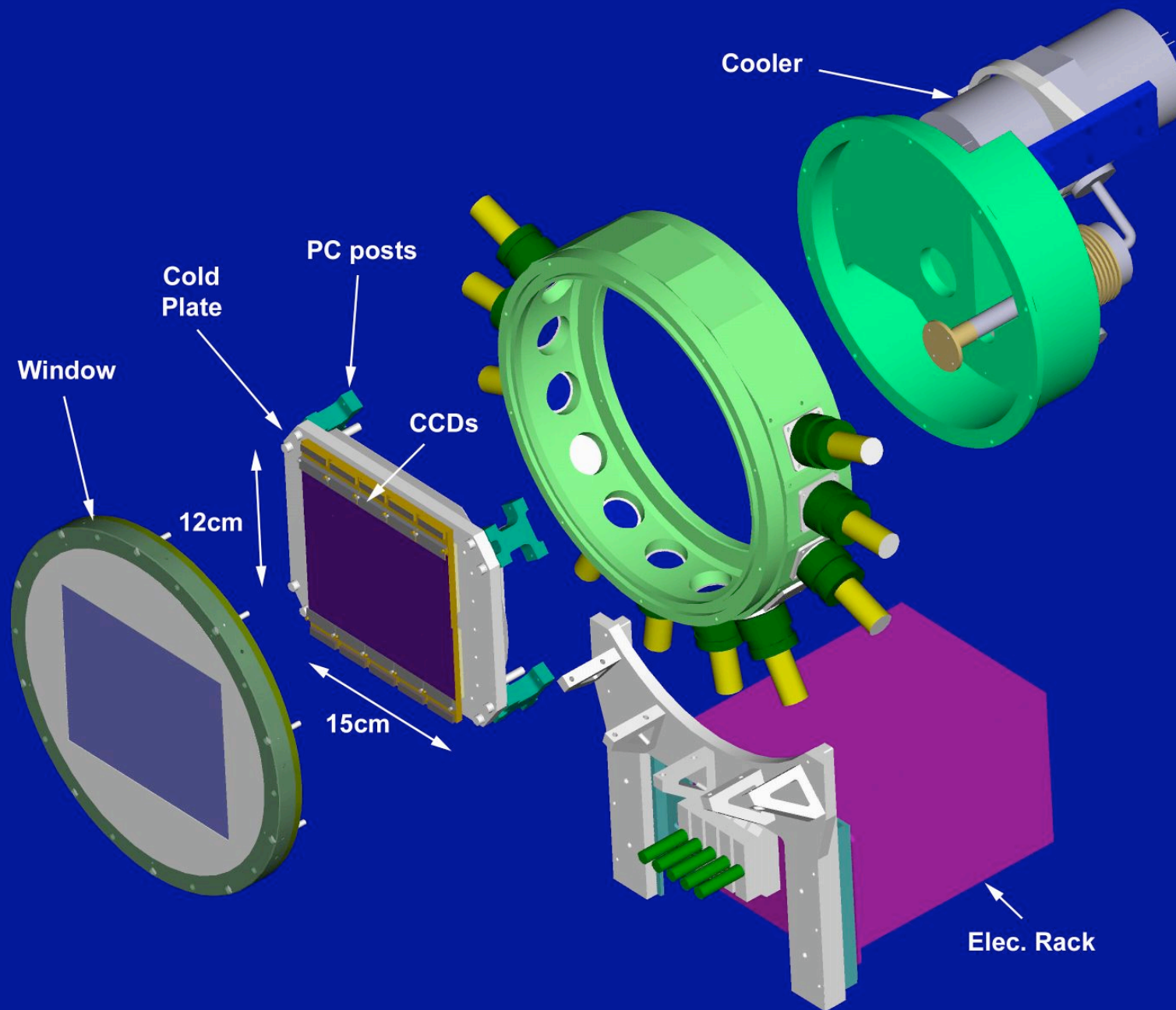

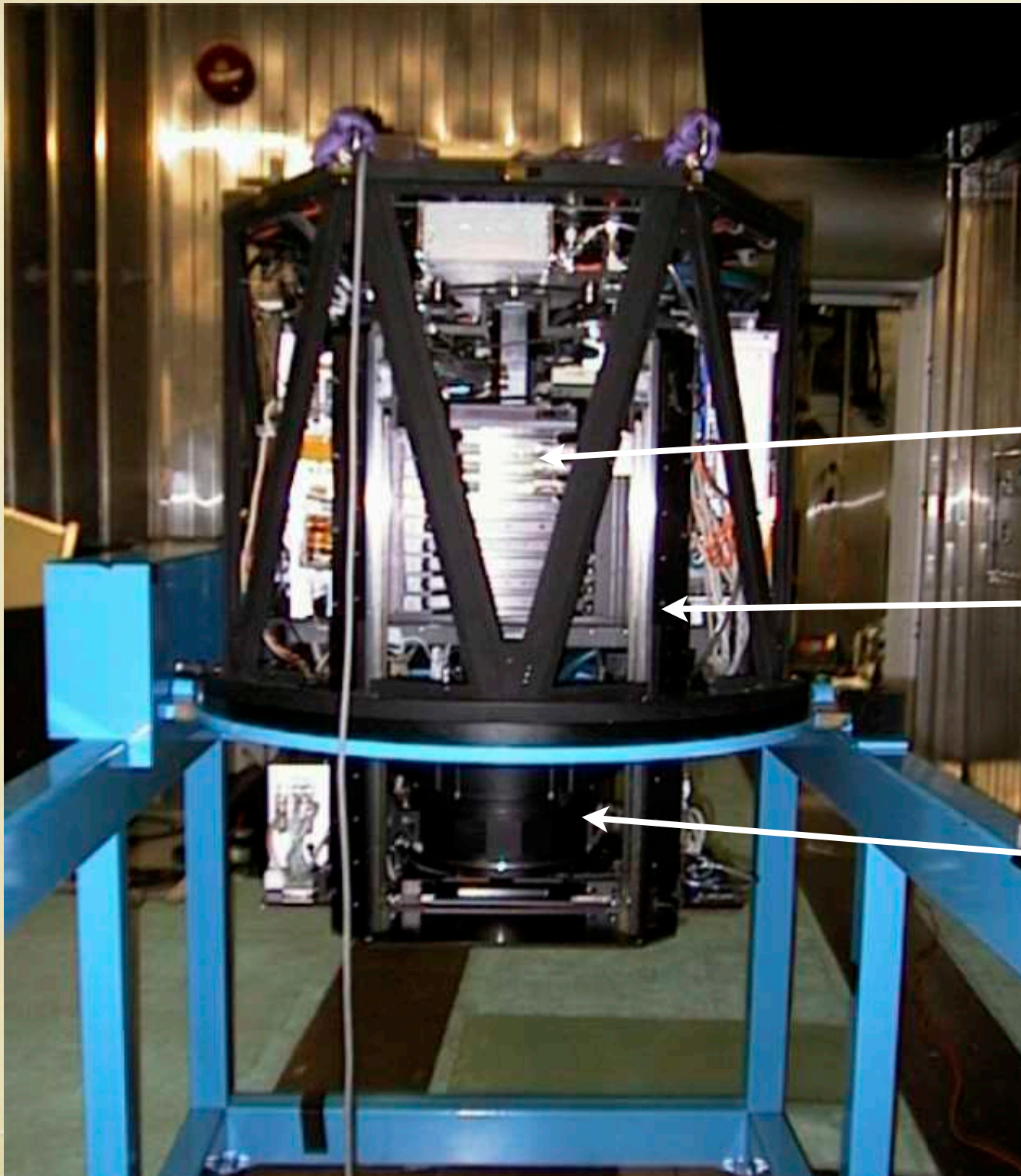

Suprime-Cam

filter juke box

filter elevator

Dewar

Prime Focus Unit



Prime Focus Unit
(Lens, Attitude Control,
Cable wrapper)

Mounting on the telescope



Top Unit Exchanger (TUE)

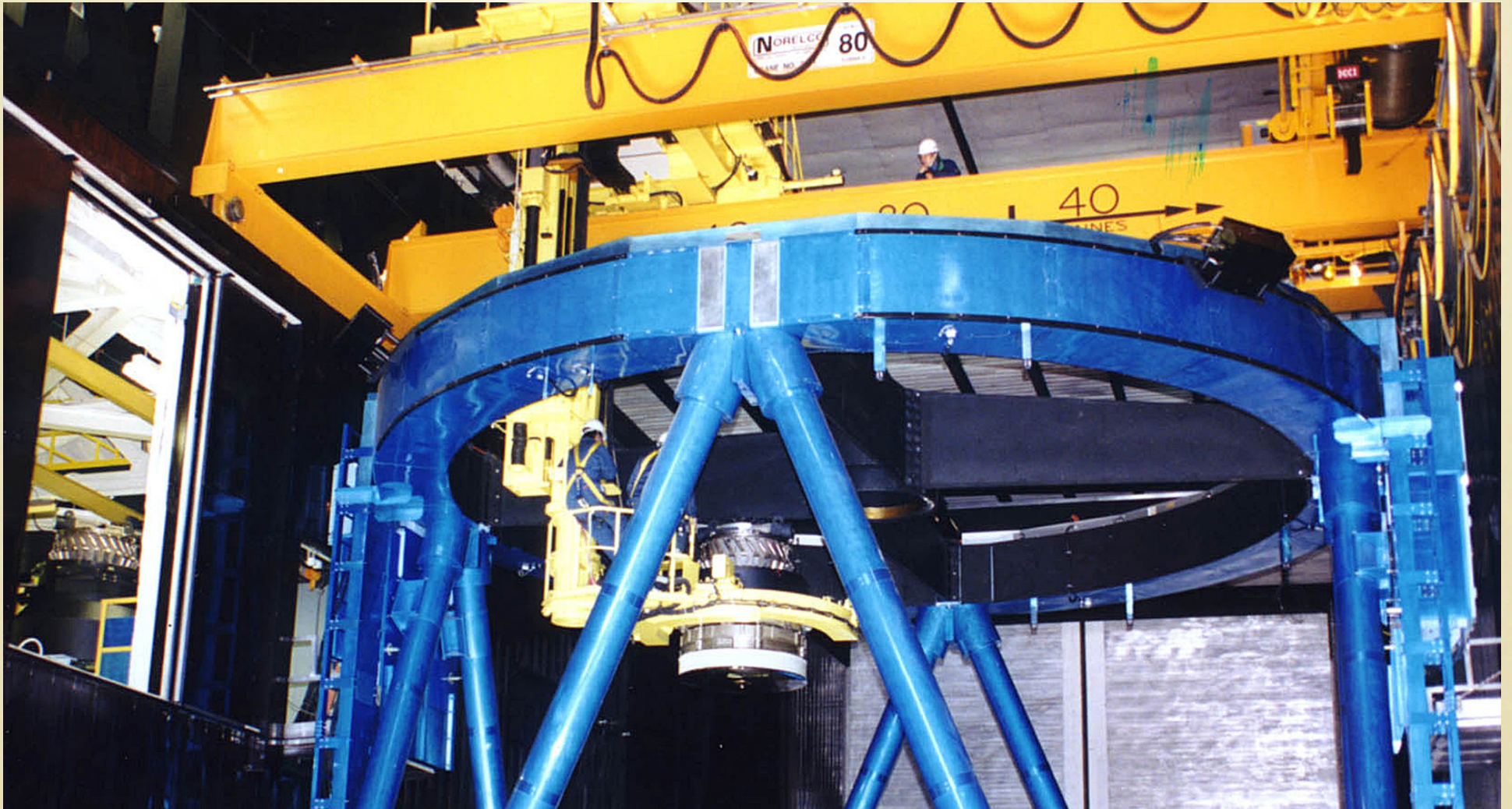

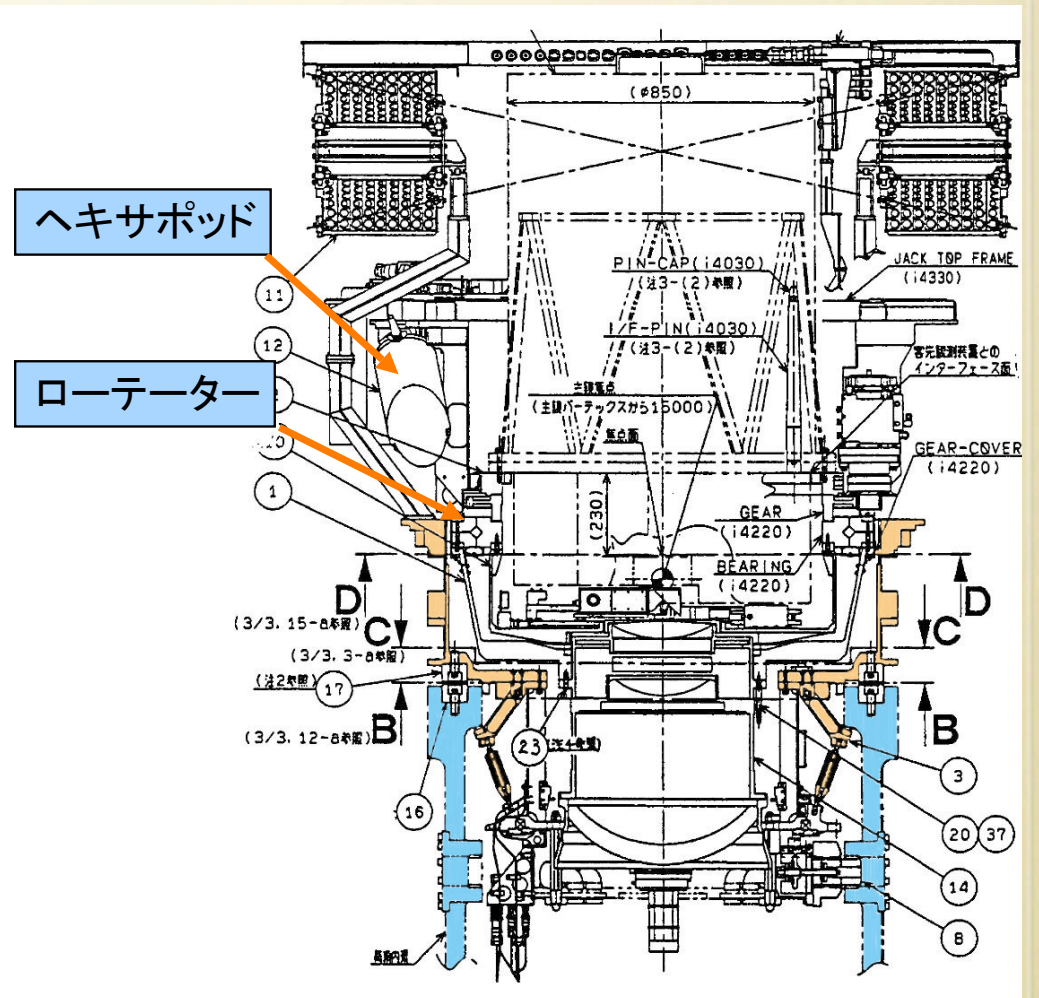
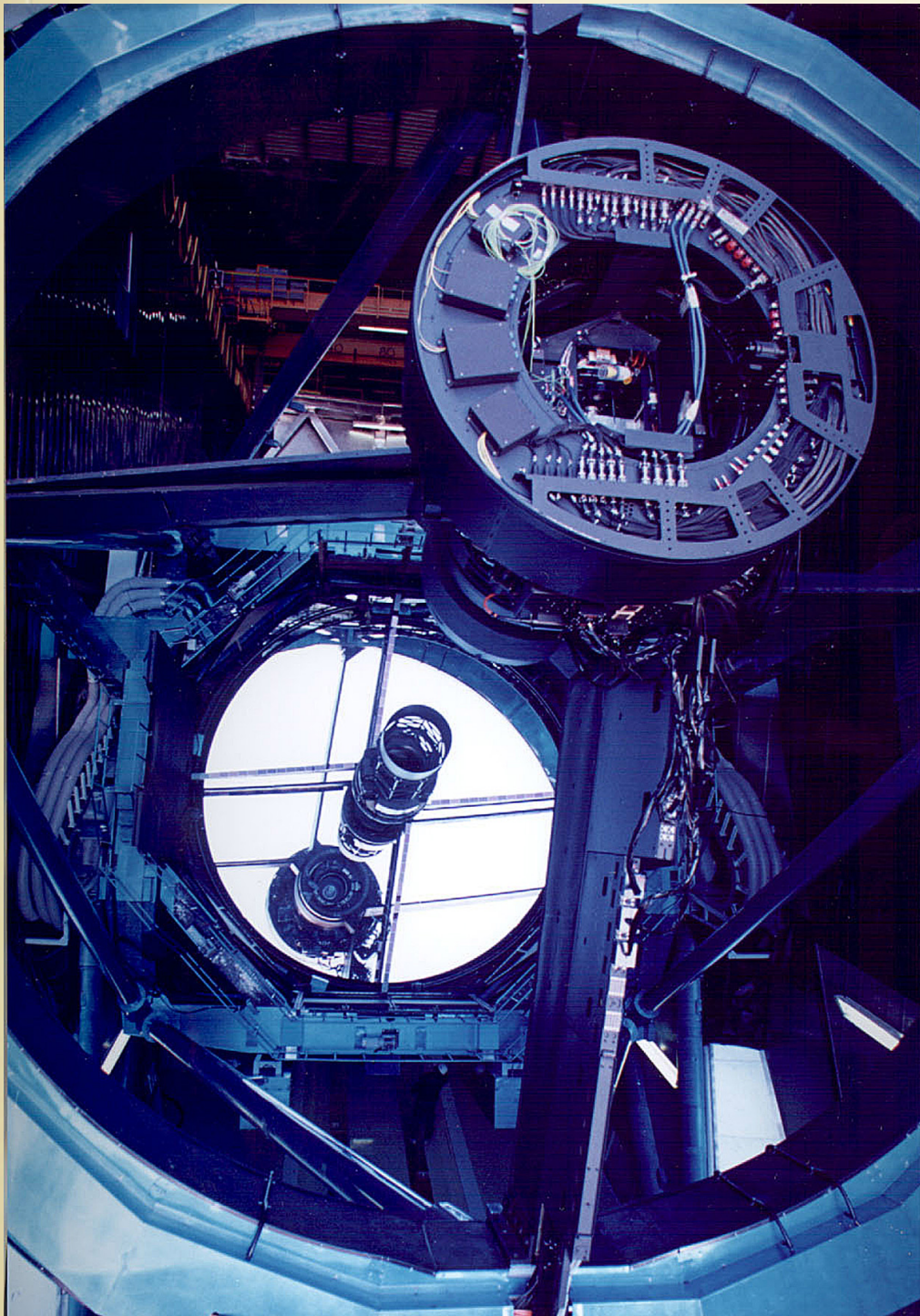



NGC 253 (B, V, I_c)



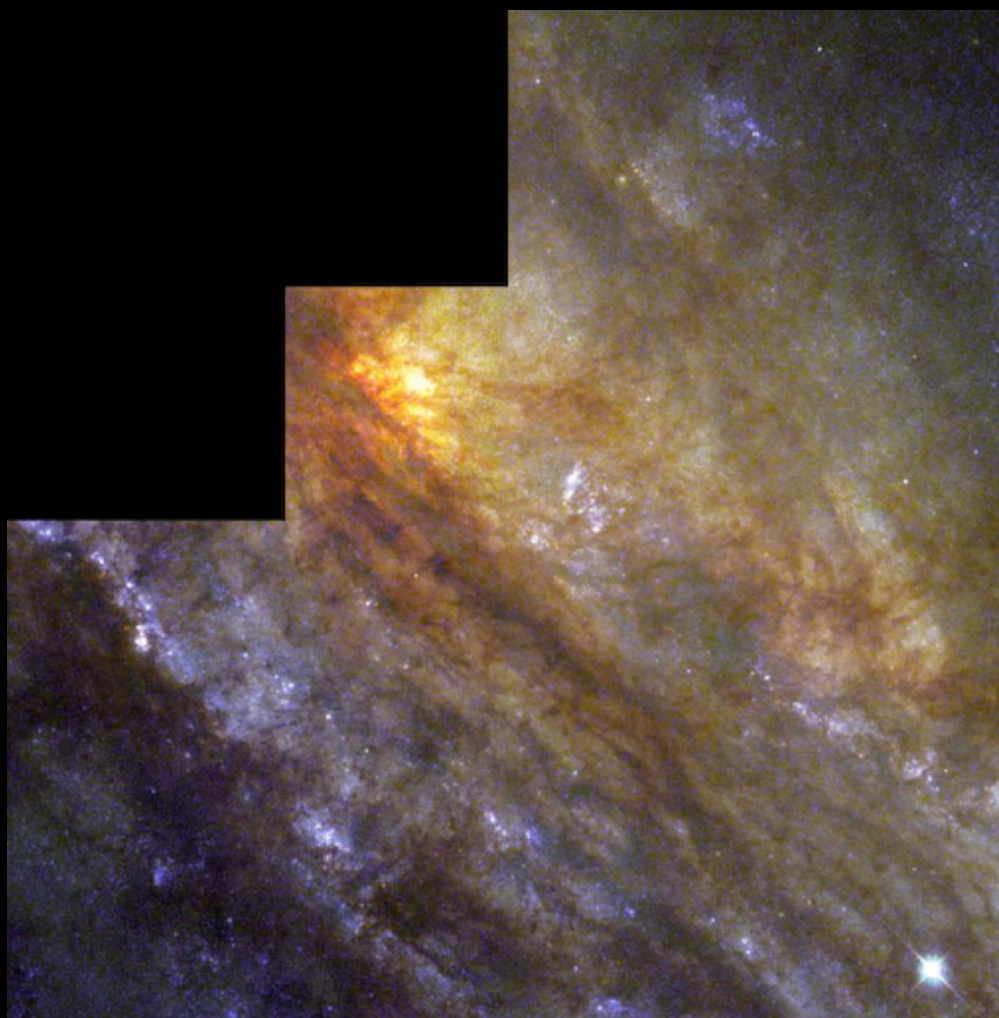

HST WFPC2
(All FOV)



Suprime-Cam
(FOV/100)

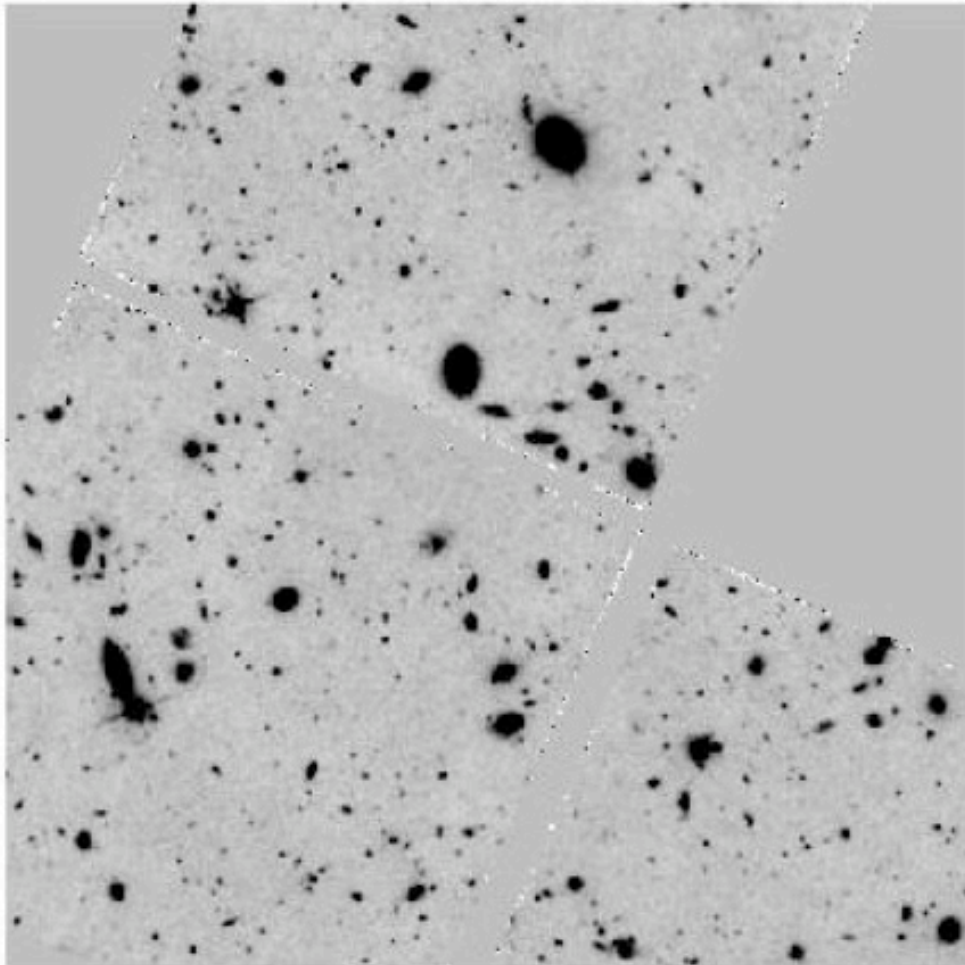

HST 'wide-I' continuum

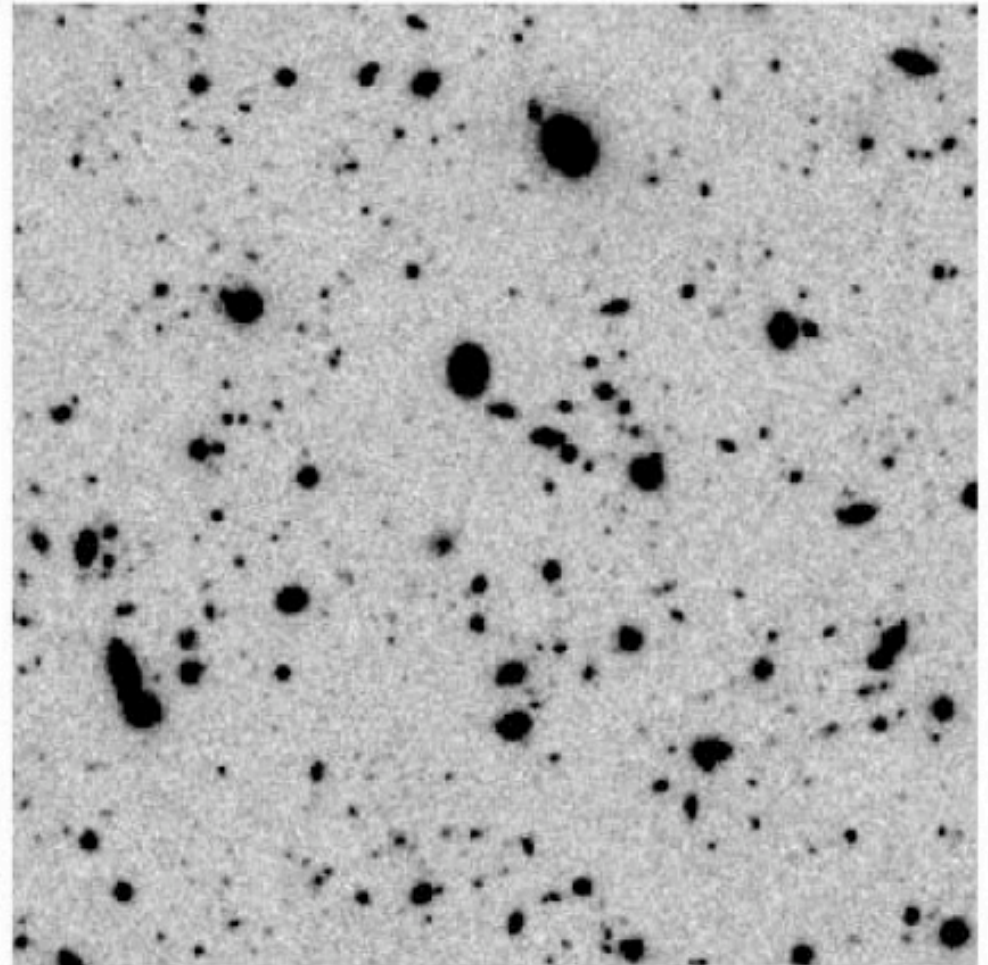

NB816 narrowband

HST WFPC2
(All FOV)

Suprime-Cam
(FOV/100)

SUPRIME-CAM

- Large Aperture
- Superb Img Qlty
- Wide Field
- High QE in red

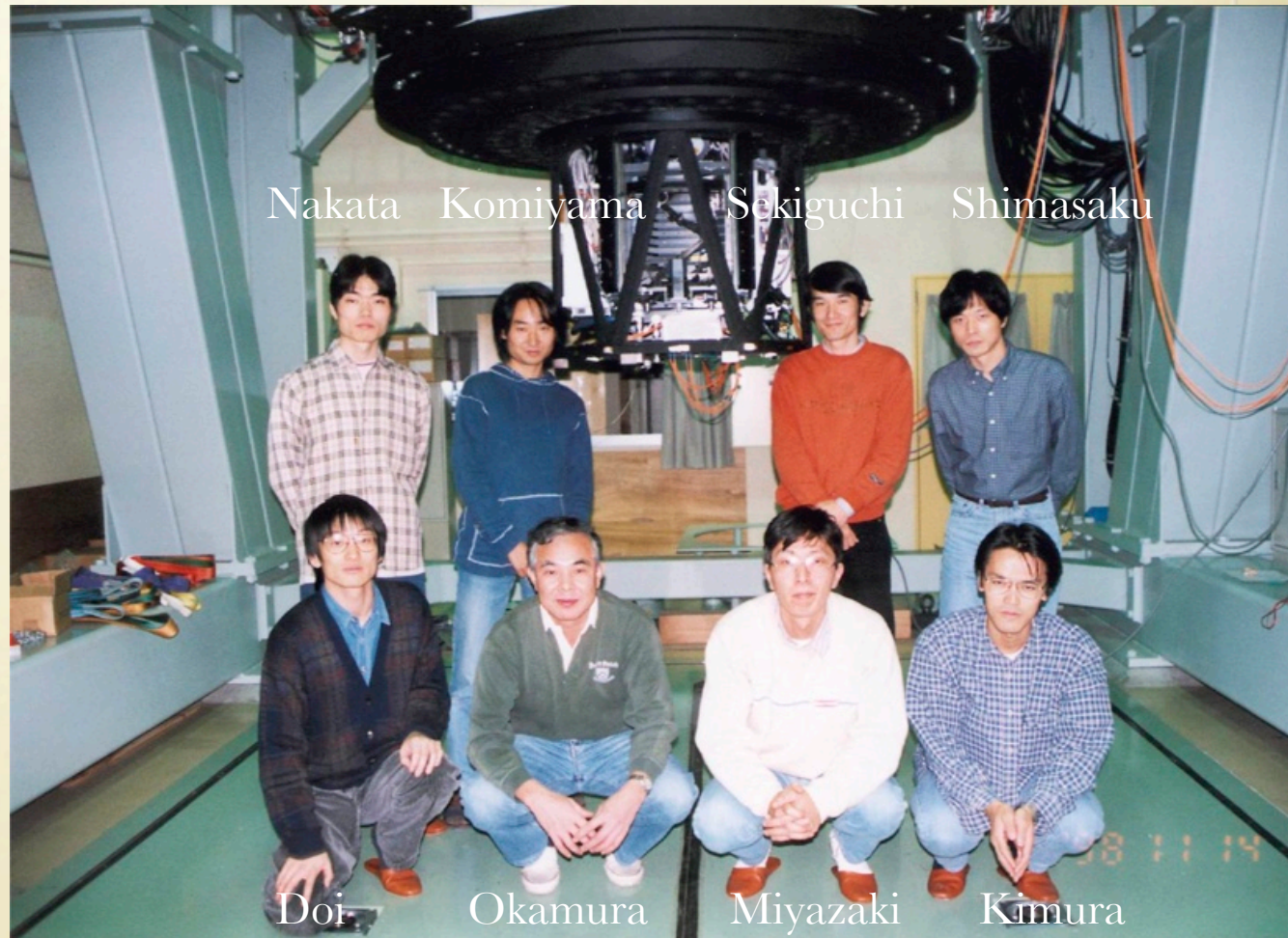

HIGH REDSHIFT GALAXIES

Table 1: The most distant galaxies with measured redshift (as of Sep.14, 2006).

Rank	Identification	Coordinates	Redshift	Distance [#]	Paper	Publishing date
1	IOK-1	J132359.8+272456	6.964	12.8826	Iye et al.	Sep. 14, 2006
2	SDF ID1004	J132522.3+273520	6.597	12.8250	Taniguchi et al.	Feb, 25, 2005
3	SDF ID1018	J132520.4+273459	6.596	12.8248	Kashikawa et al.	Apr. 25, 2006
4	SDF ID1030	J132357.1+272448	6.589	12.8238	Kashikawa et al.	Apr. 25, 2006
5	SDF ID1007	J132432.5+271647	6.580	12.8222	Taniguchi et al.	Feb. 25, 2005
6	SDF ID1008	J132518.8+273043	6.578	12.8219	Taniguchi et al.	Feb. 25, 2005
6	SDF ID1001	J132418.3+271455	6.578	12.8219	Kodaira et al.	Apr. 25, 2003
8*	HCM-6A	J023954.7-013332	6.560	12.8189	Hu et al.	Apr. 1, 2002
9	SDF ID1059	J132432.9+273124	6.557	12.8184	Kashikawa et al.	Apr. 25, 2006
10	SDF ID1003	J132408.3+271543	6.554	12.8178	Taniguchi et al.	Feb.25, 2005

[#] Distance in billion light years calculated for a model of the Universe that has an age 13.66 billion years.
^{*} This object was discovered by Keck telescope. All the rest were discovered by Subaru Telescope in the Subaru Deep Field.

Good example to show Suprime-Cam strength

HYPER SUPRIME

Expand the Suprime-Cam FOV

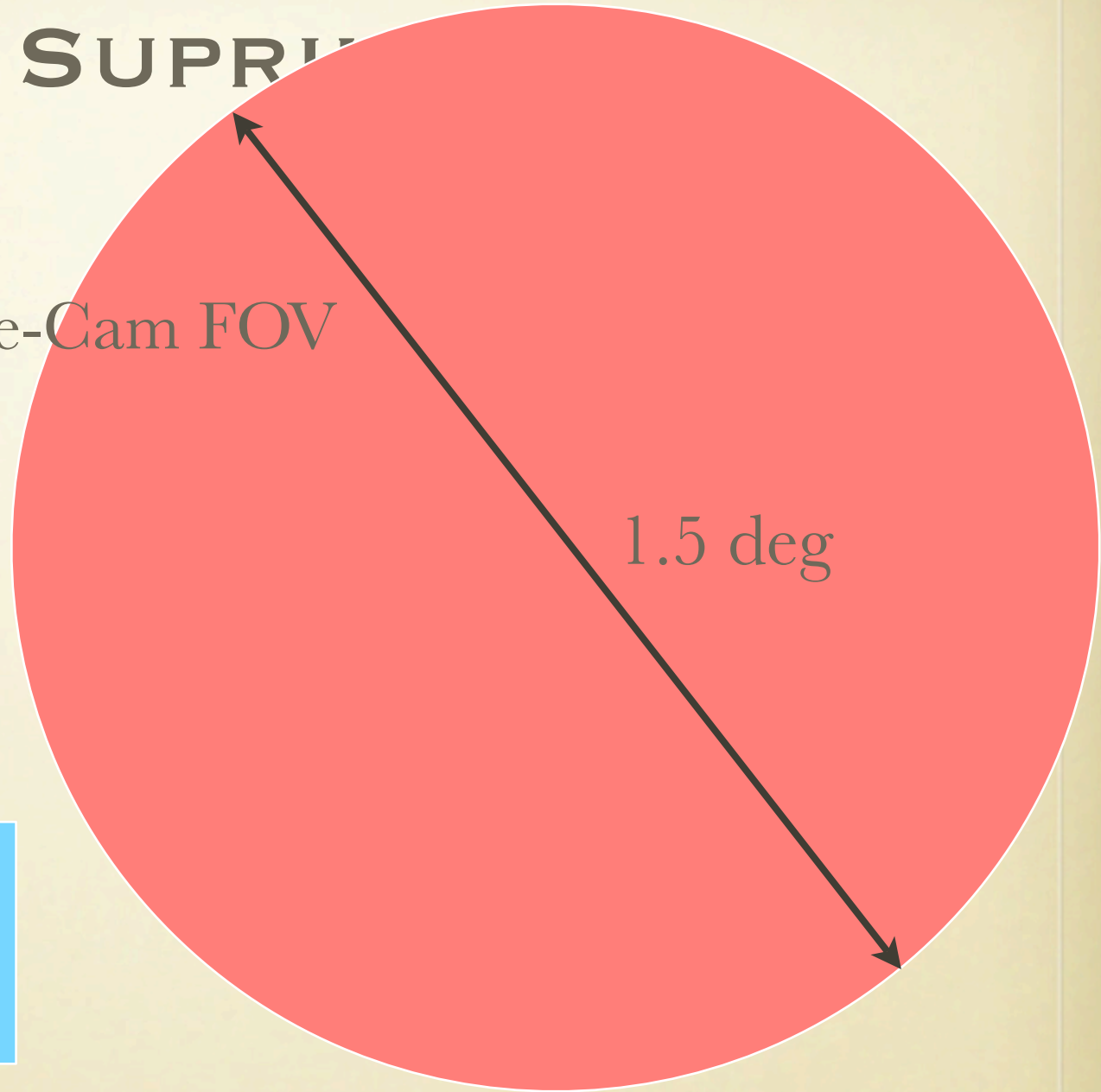

HST

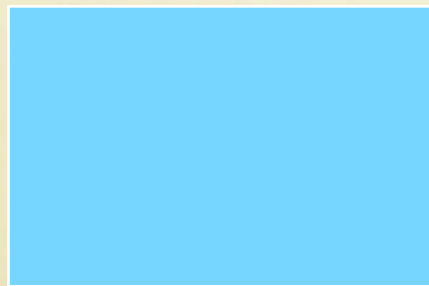

Suprime-Cam

HSC

HYPER SUPRIME-CAM CONFIG

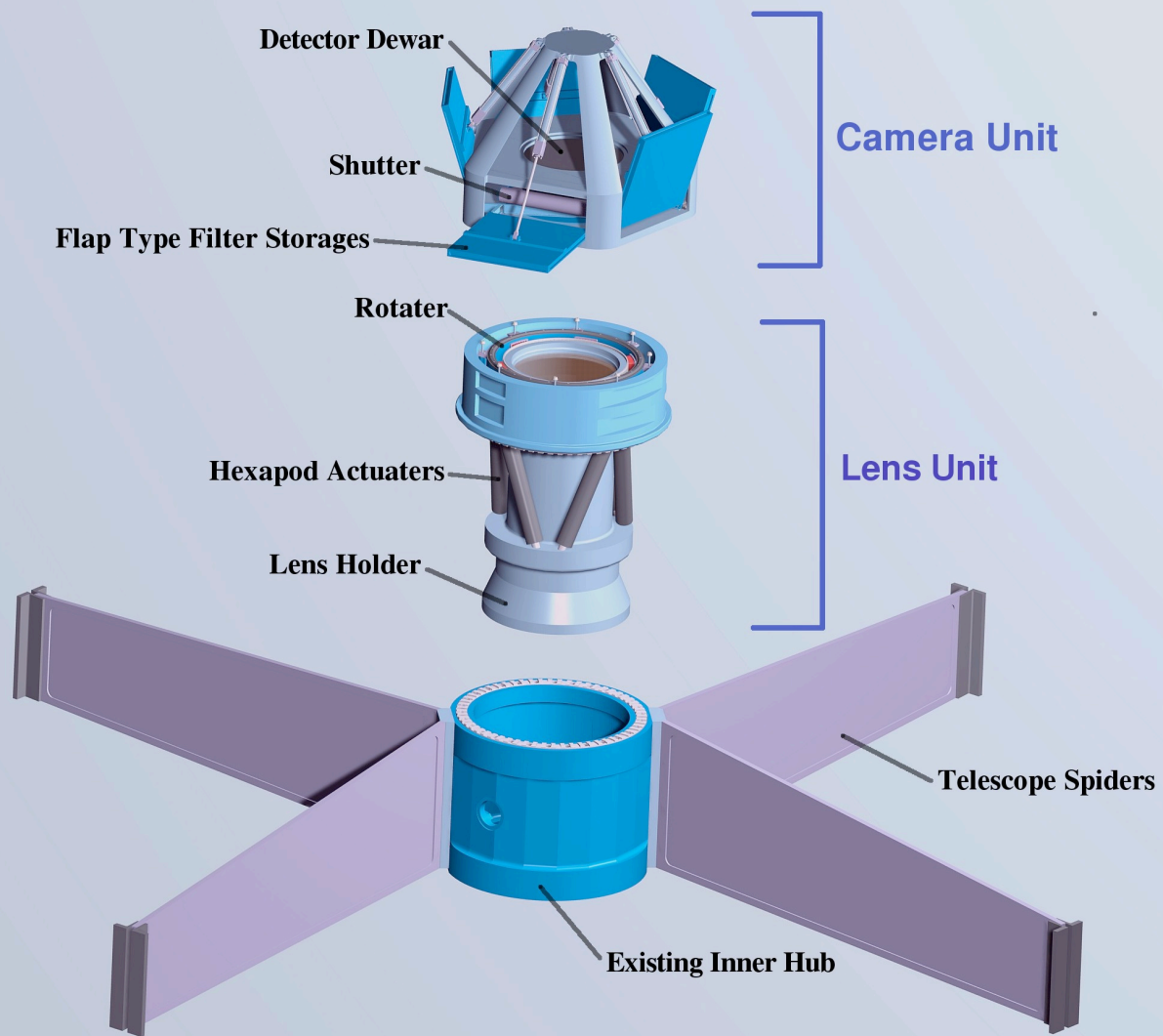

HSC SIDE VIEW

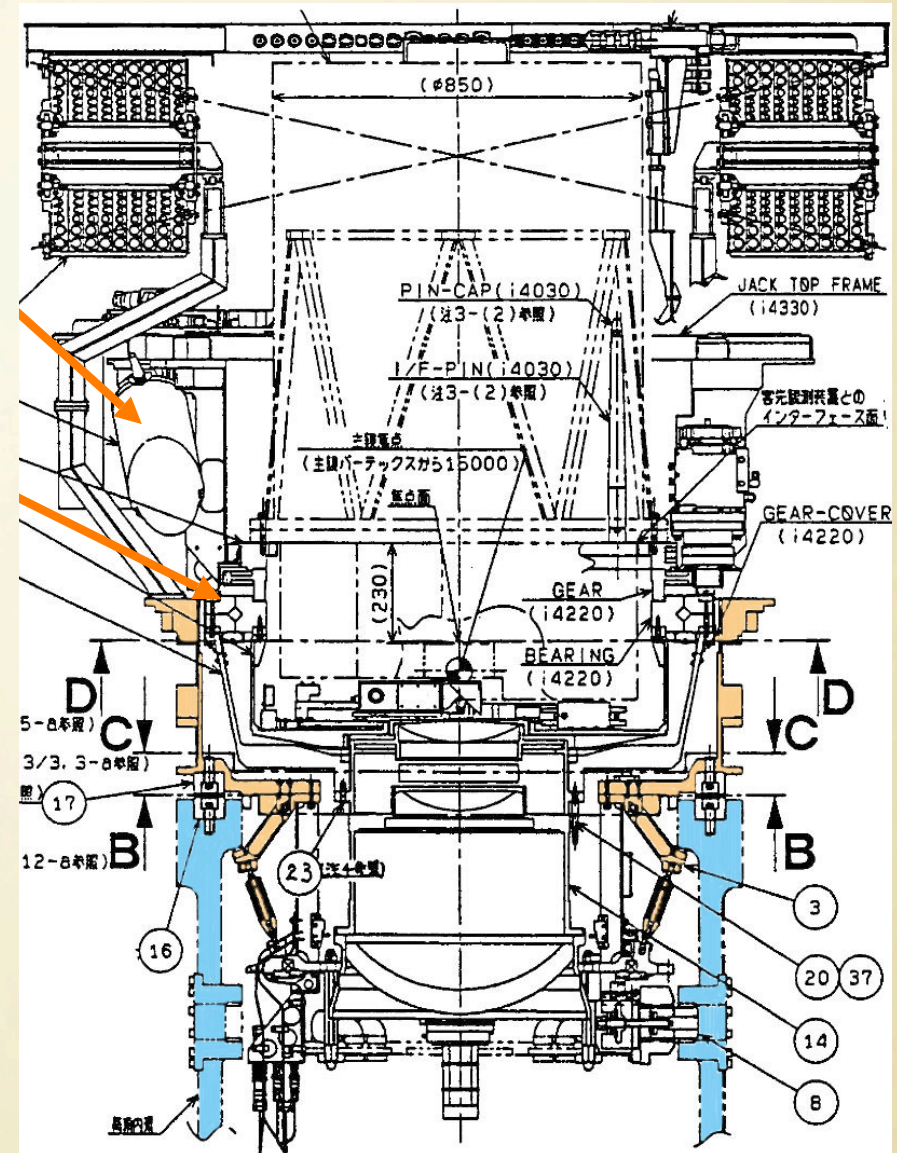
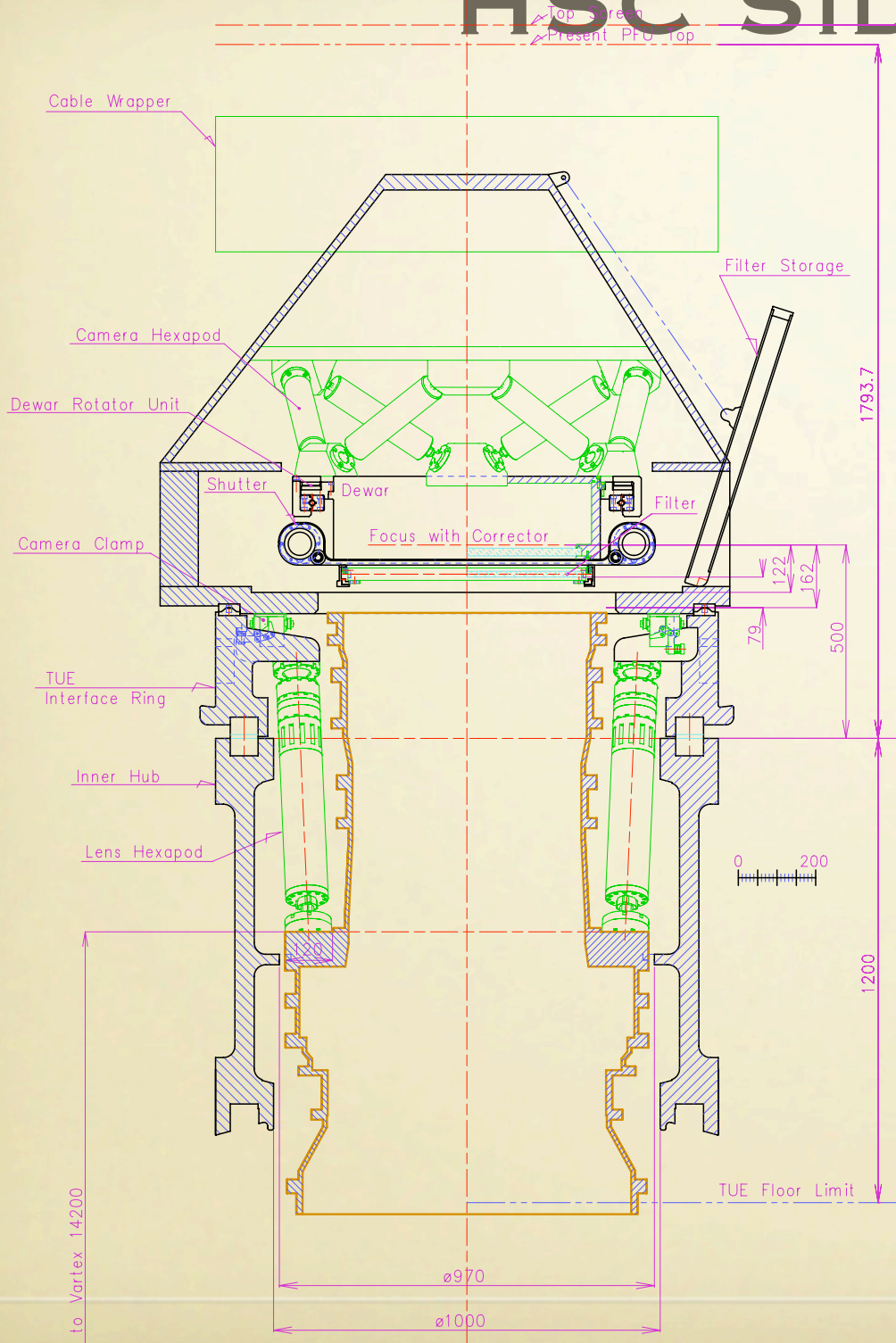

HSC WFC NAOJ DESIGN

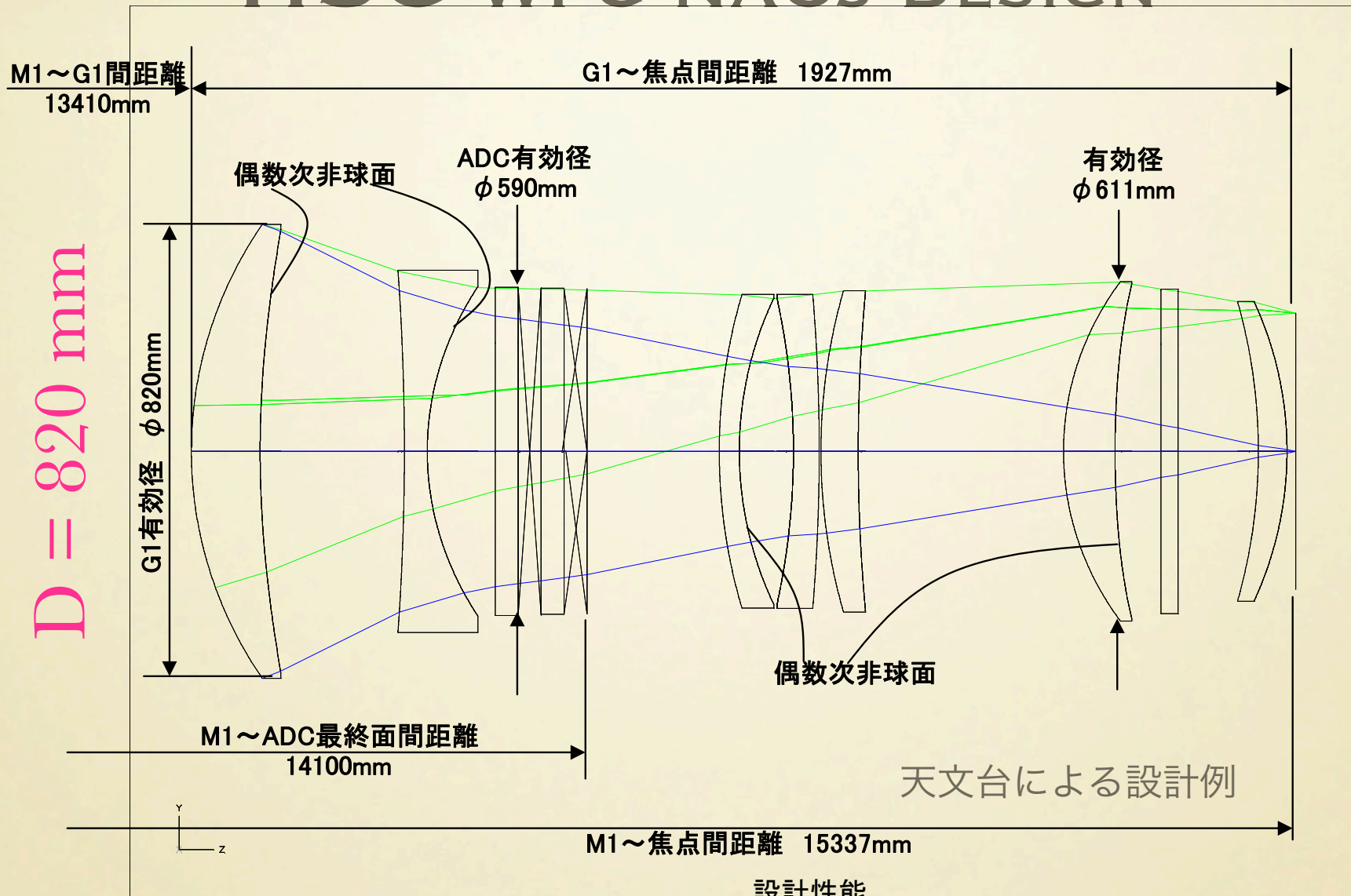

Silica for large Lens
Large aspheric surface

設計性能

	EL = 90				
	WF MOS	g	r	i	z
r80(um)	12	11.2	7.6	7.8	9.6
D80(sec)	0.264	0.246	0.167	0.171	0.211

Img Qlty equivalent with SC

HSC OPTICS

Canon

Final design considering manufacturability

Detail tolerance analysis

Design of Lens Barrel

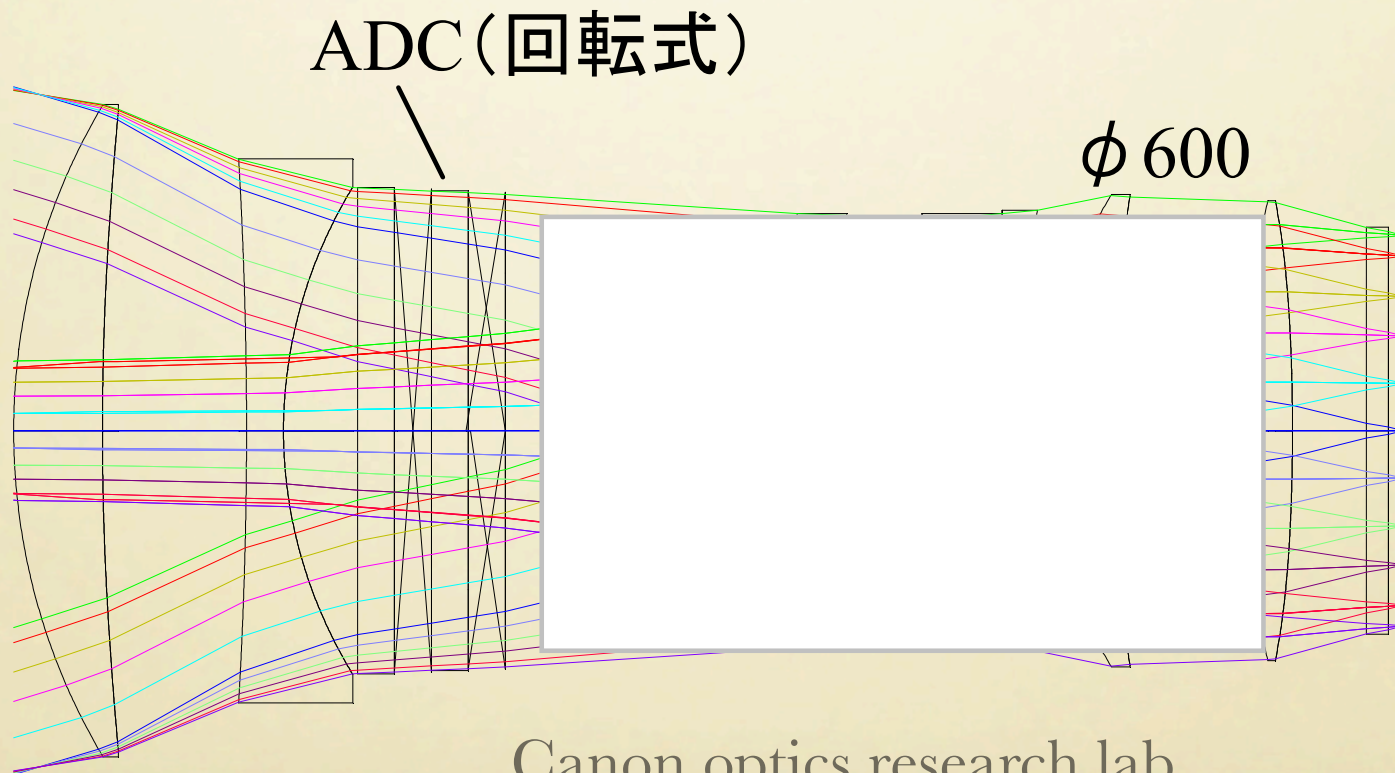

Canon optics research lab

HSC WFC ISSUES

- Tele-centricity must be improved to satisfy WFMOS specification

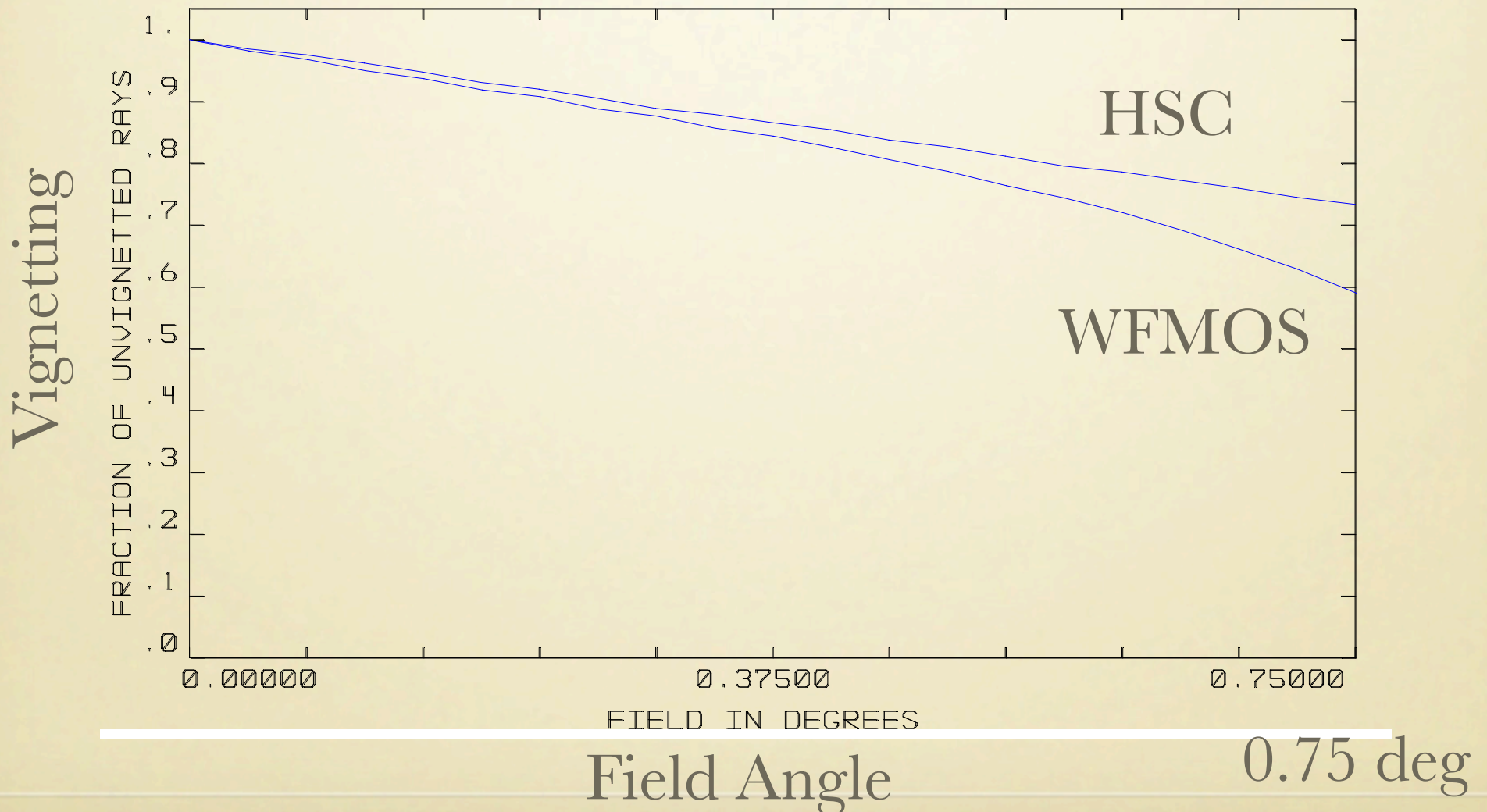

HSC DEVELOPMENT TEAM

Camera Body

NAOJ
U. Tokyo
KEK

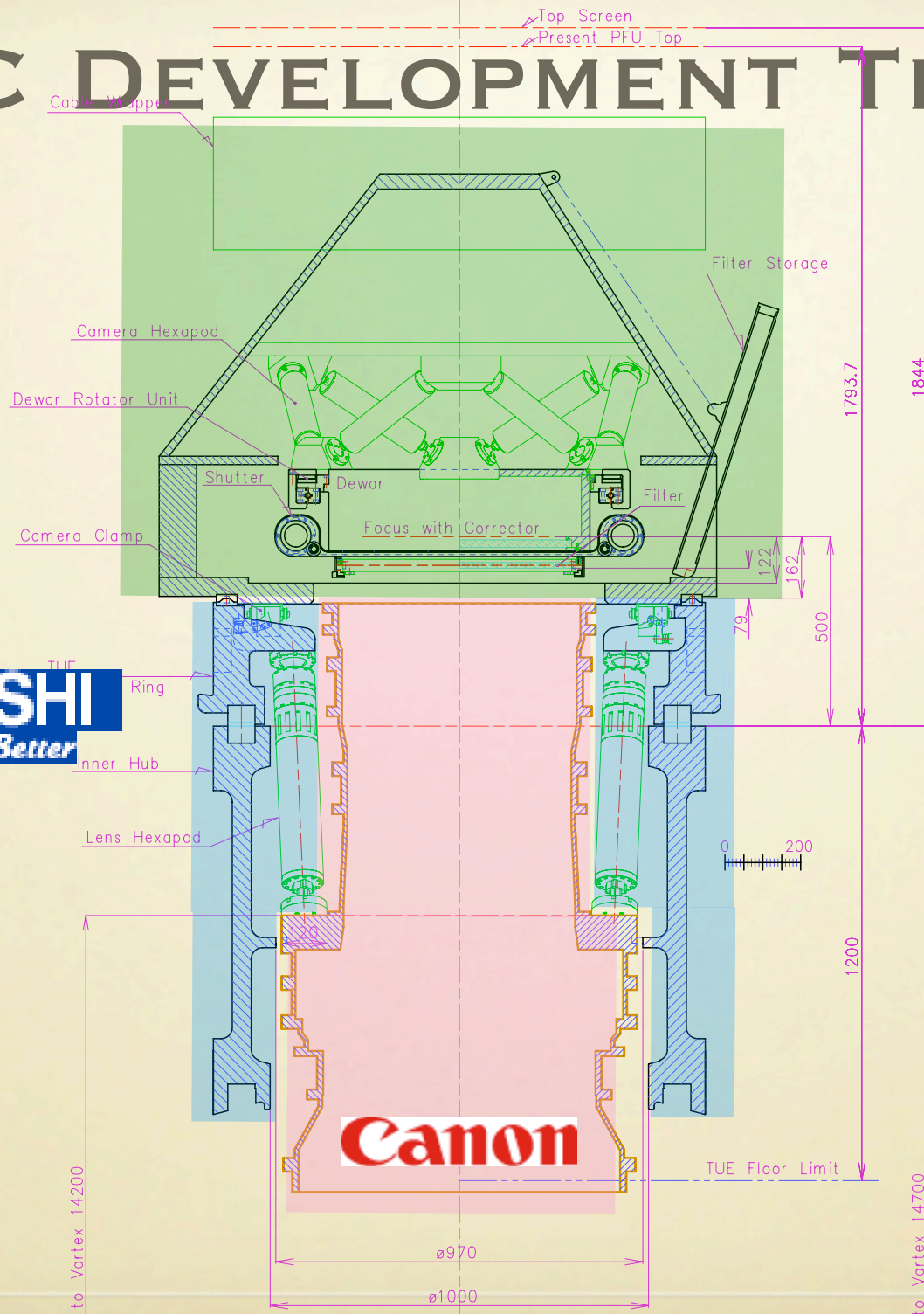

mitsubishi
Changes for the Better

Canon

CAMERA UNIT

rotator付きの最新
のにupdateする

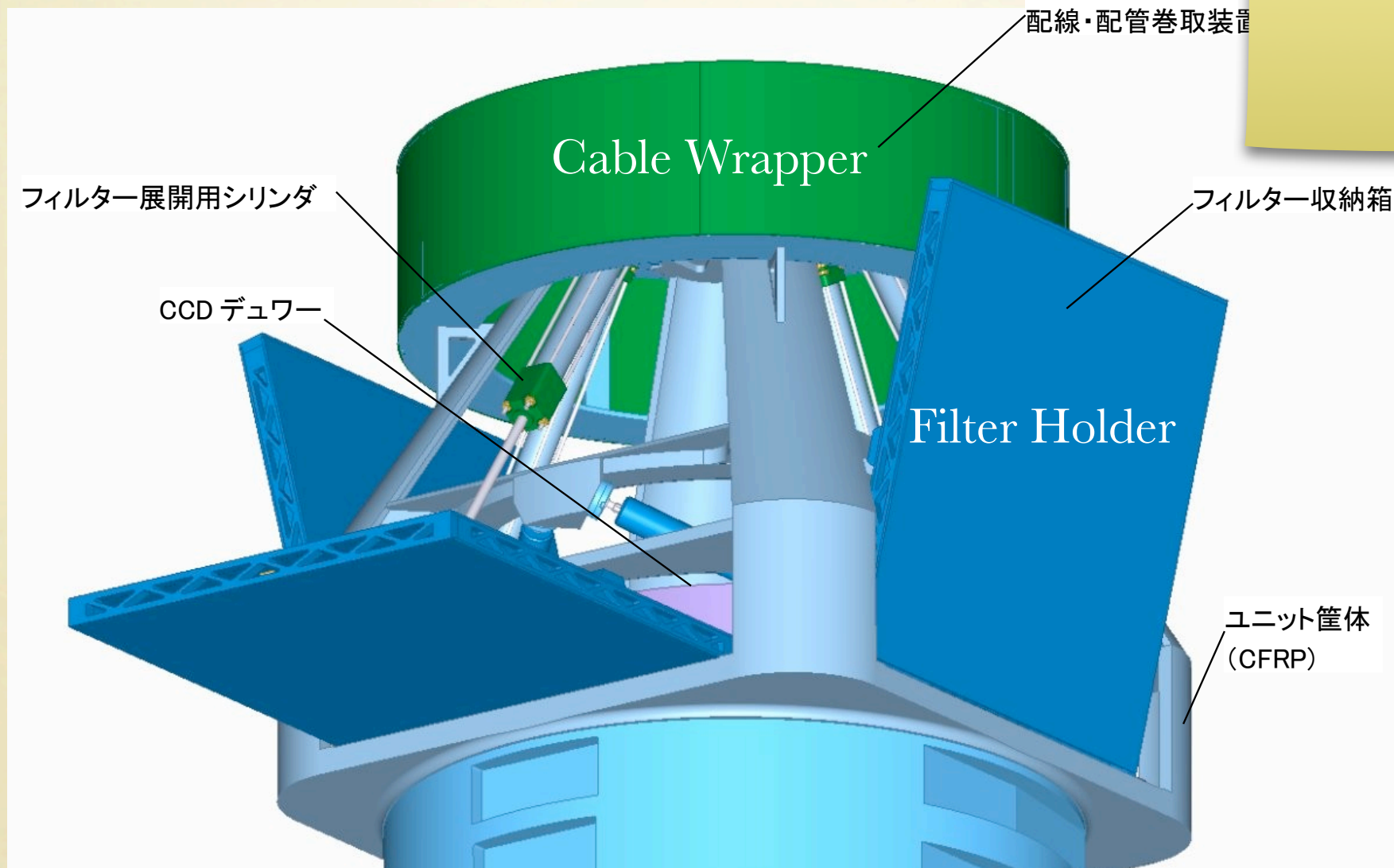

CAMERA UNIT

rotator付きの最新のものにupdateする

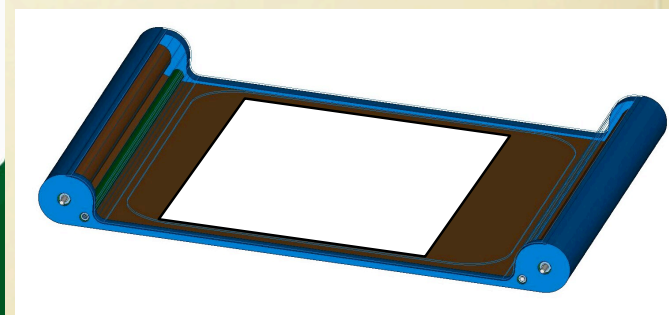
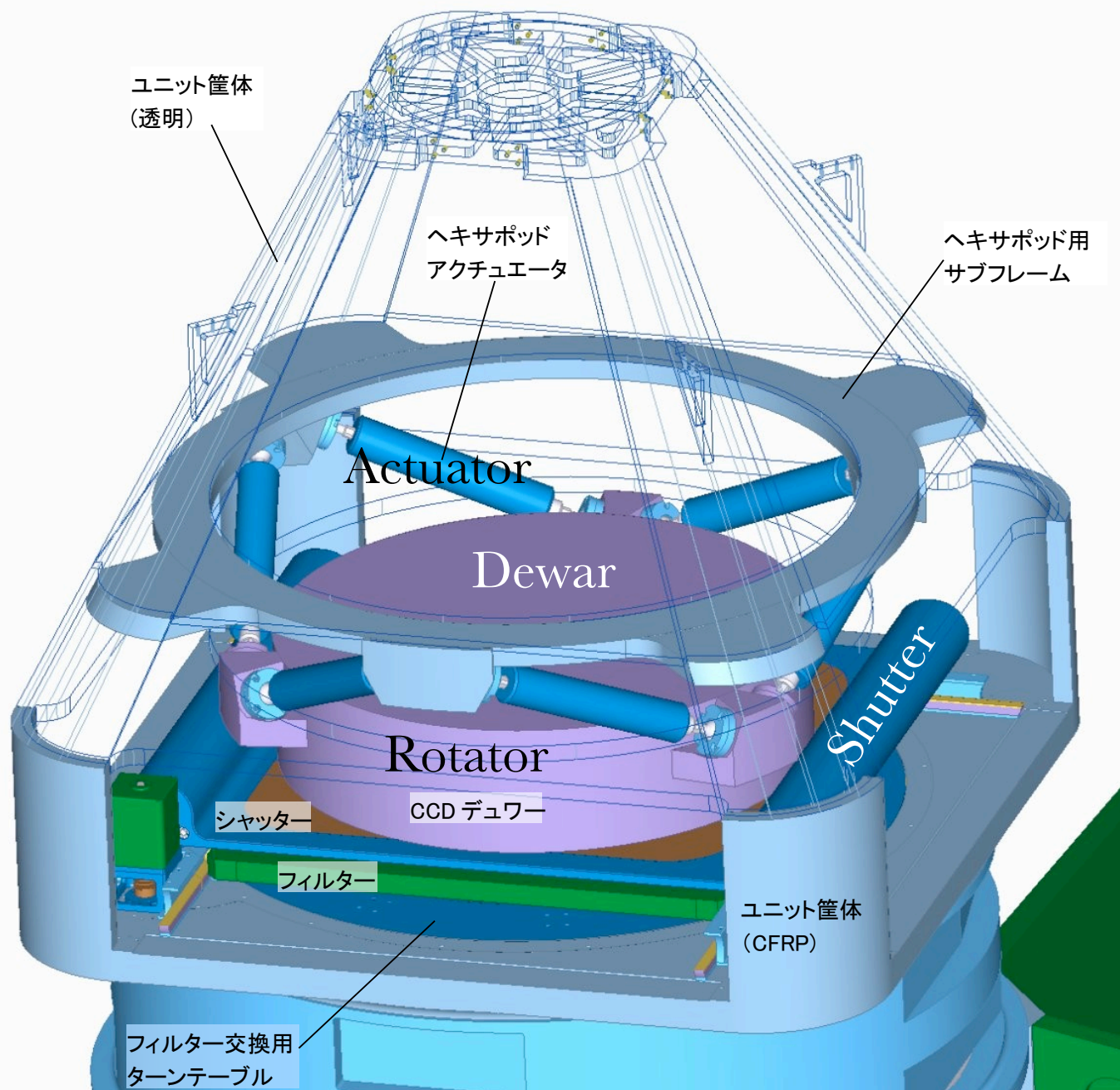

CCD DEWAR

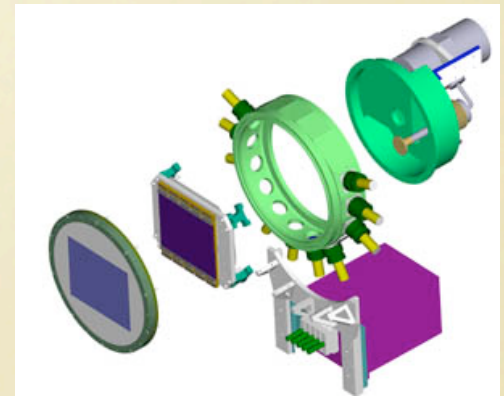
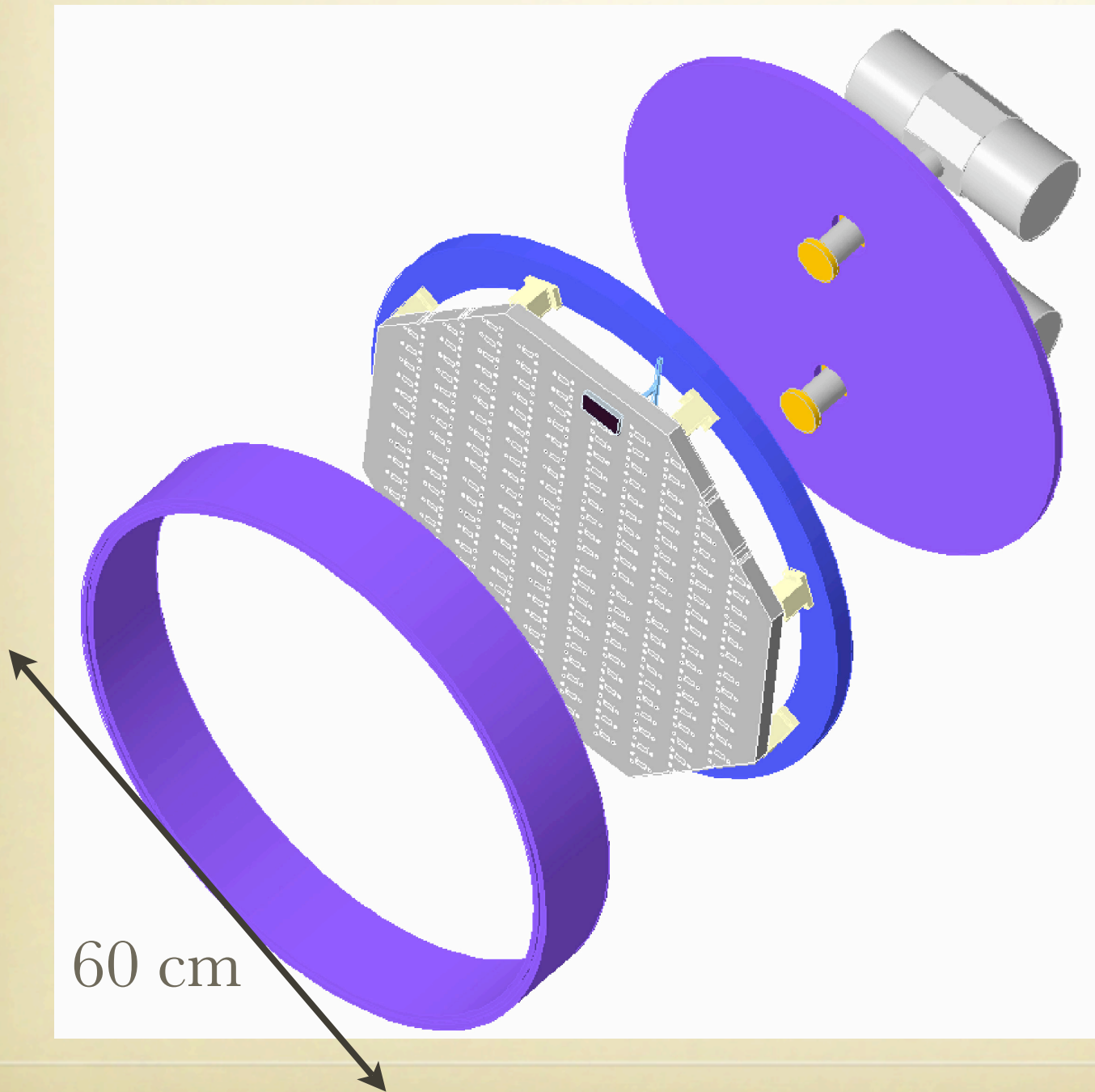

FULLY DEPLETED CCD

- Red QE drops because the CCD is transparent: need thicker depletion layer (DL) to improve it
- $d_{DL} \propto \rho$ [Ωcm]
- High ρ n-type Si is obtained through neutron dose

Merit

High QE in red

Less fringing

Easier to obtain BI CCD

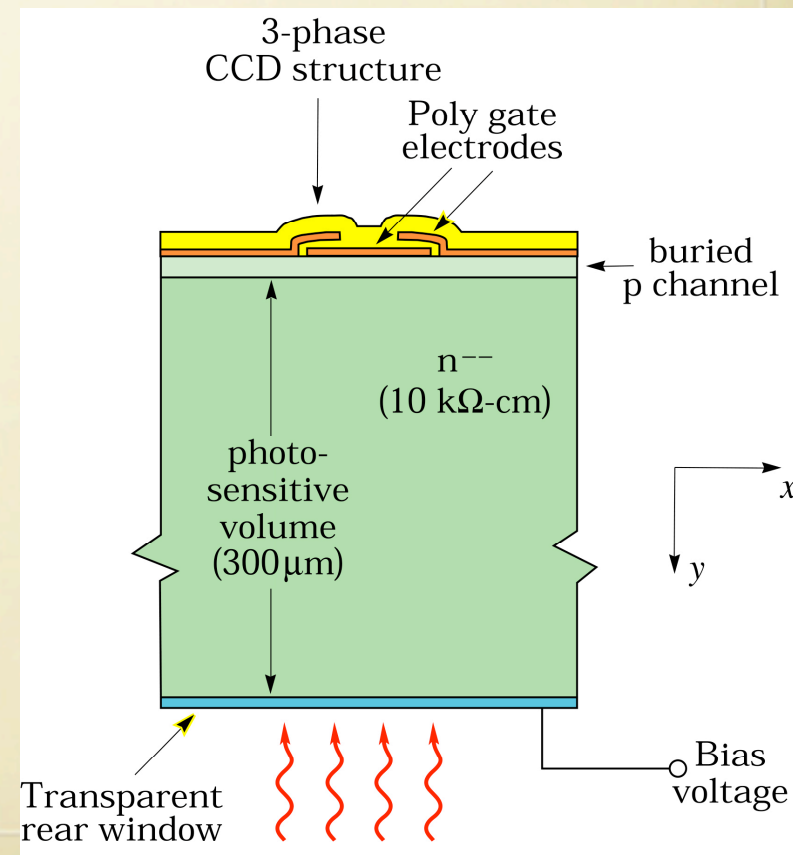

SIGNAL IS CARRIED BY HOLES

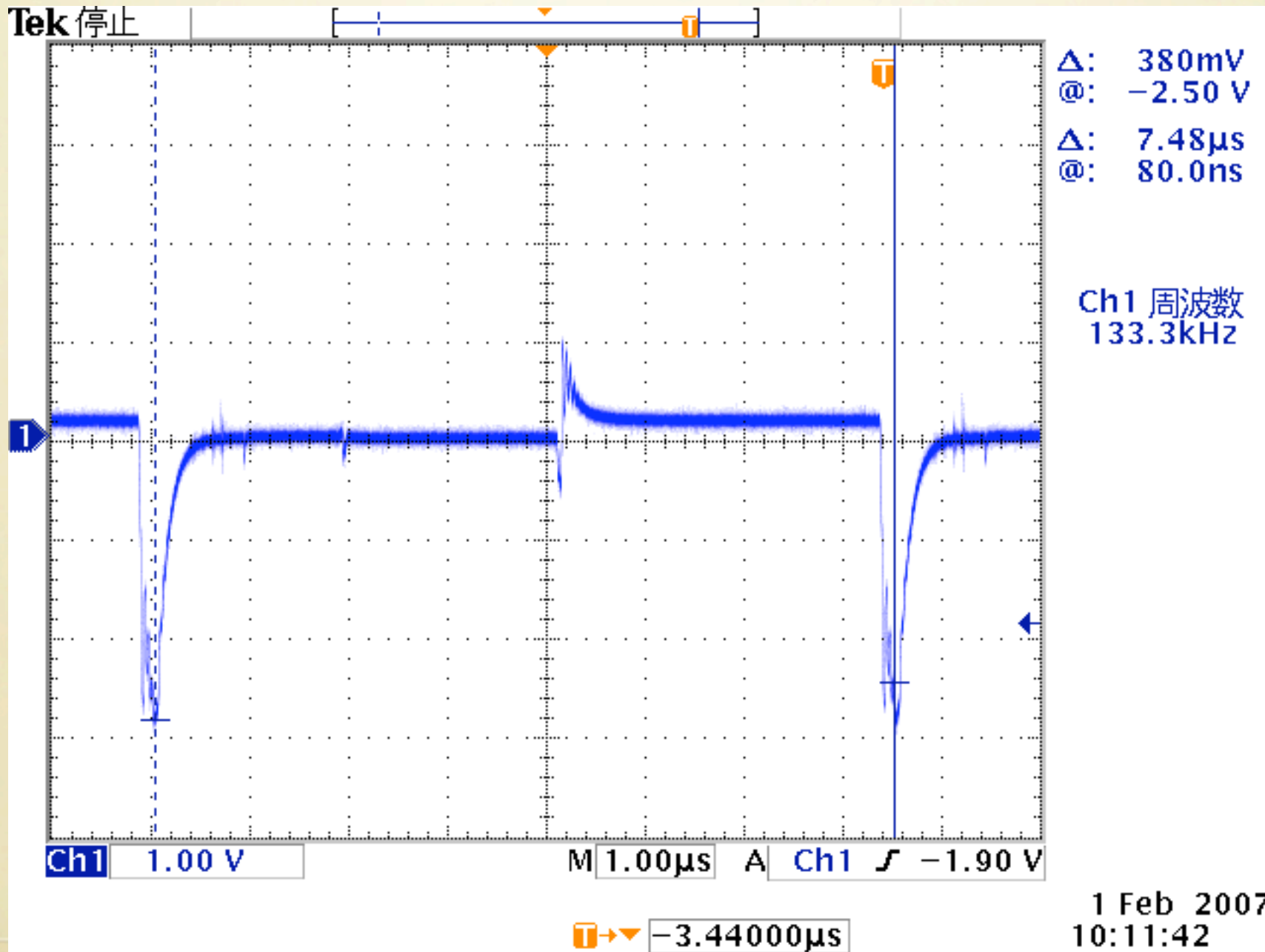

COLLABORATION WITH HPK

HAMAMATSU Japan

- 2000 NAOJ - HPK Collaboration started
- 2001 Japanese X-ray groups joined
- 2006 2k4k BI CCD delivered

HPK FDCCD

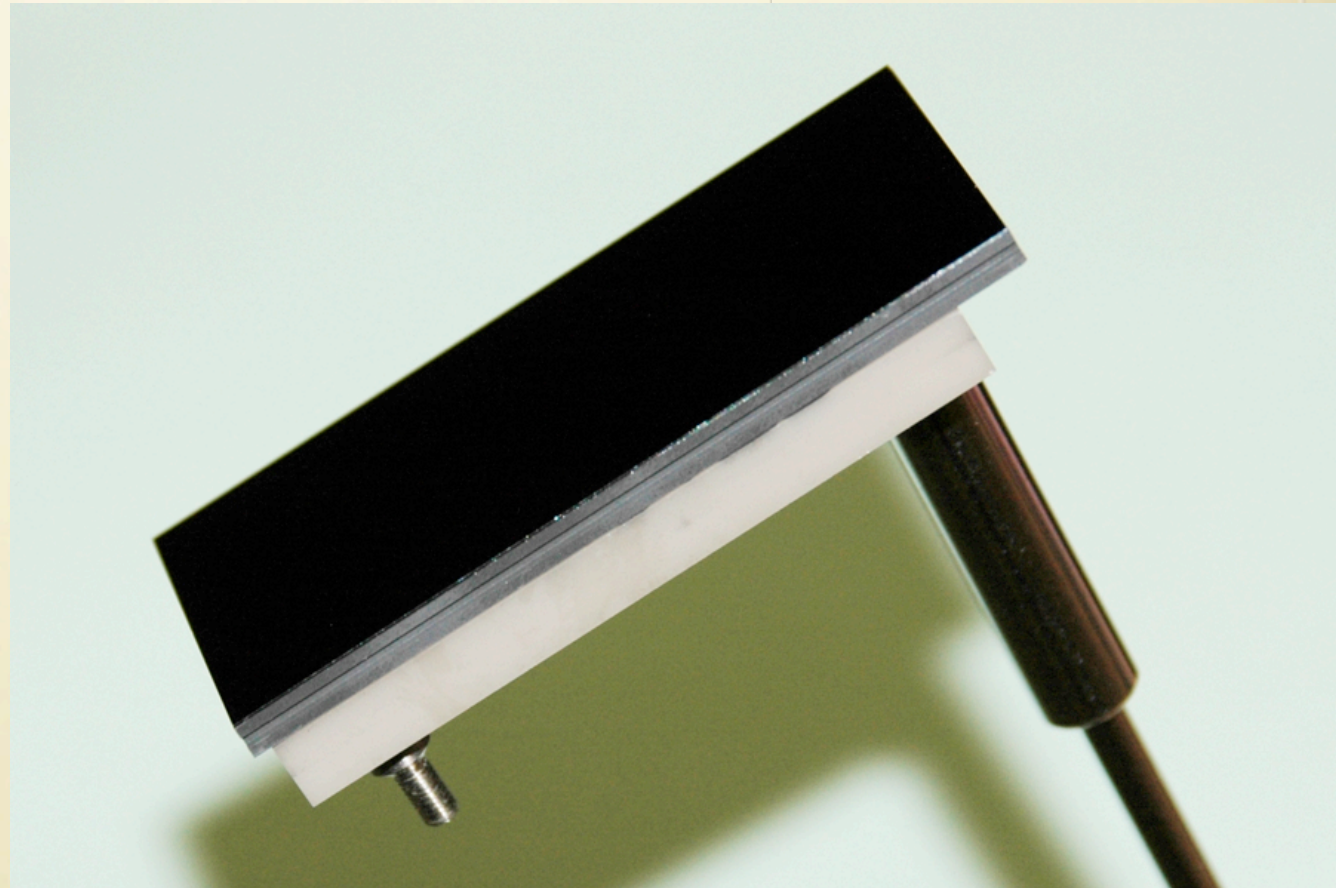
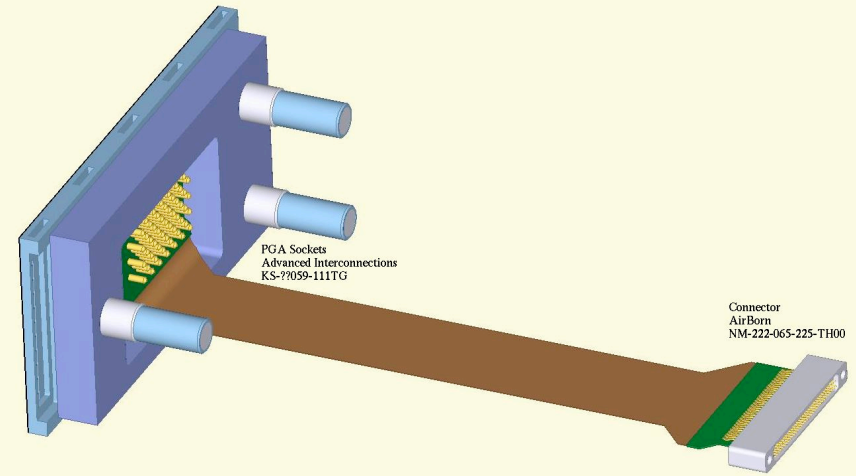
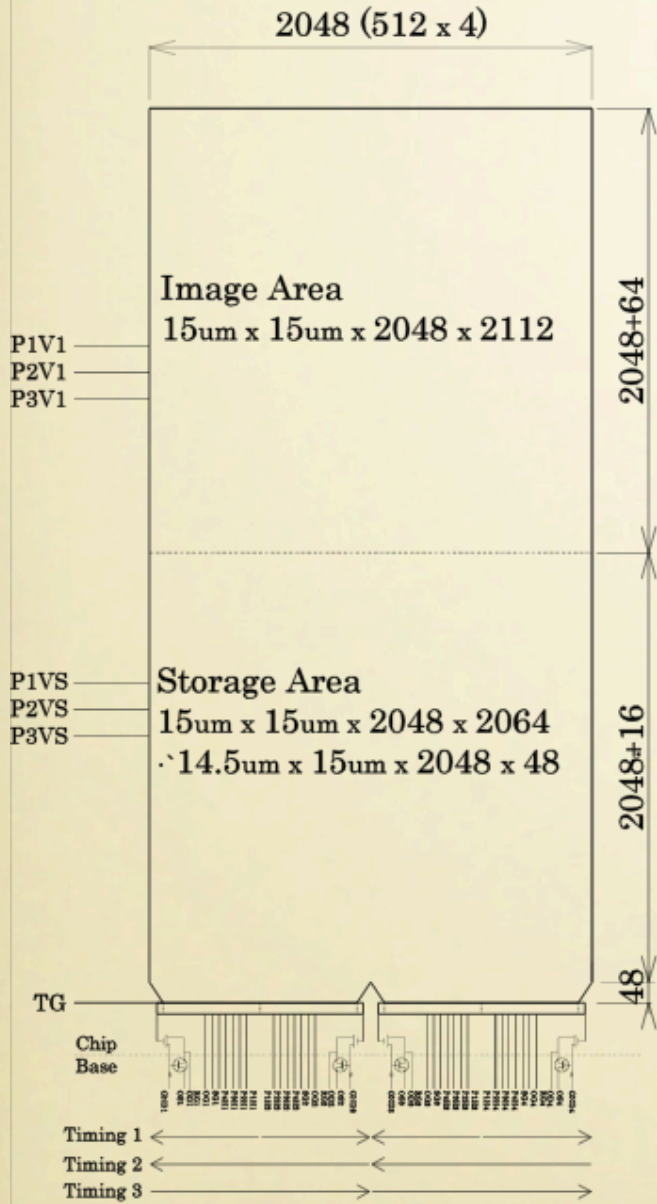

FDCCD QE

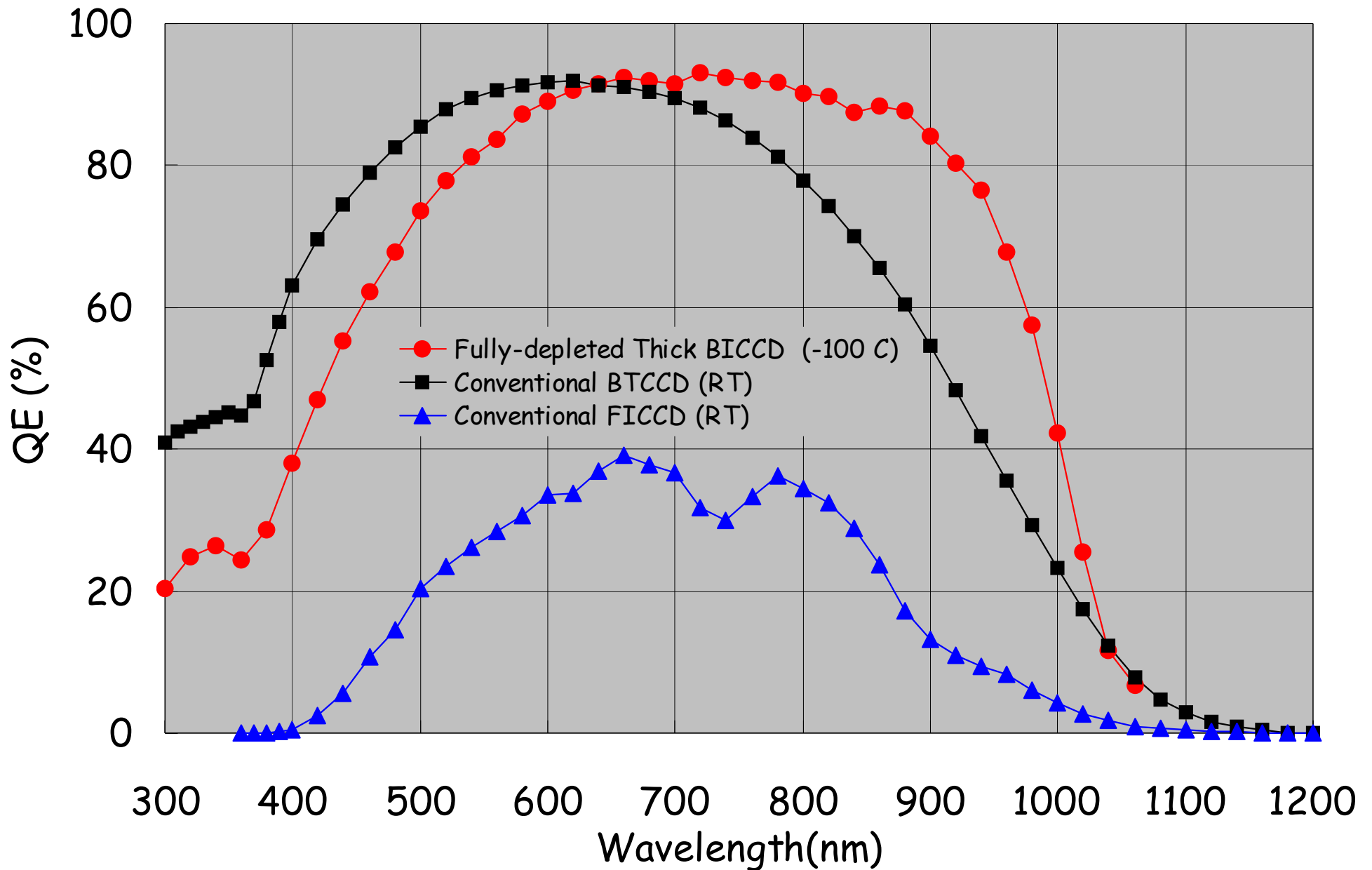

X-RAY ENERGY RESOLUTION

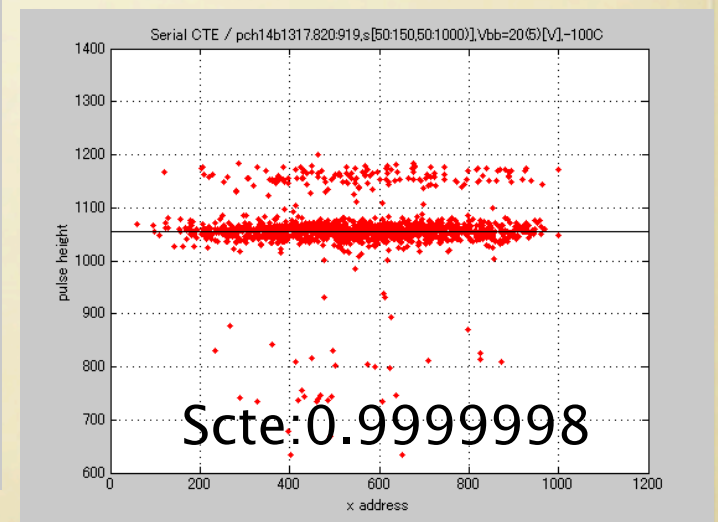
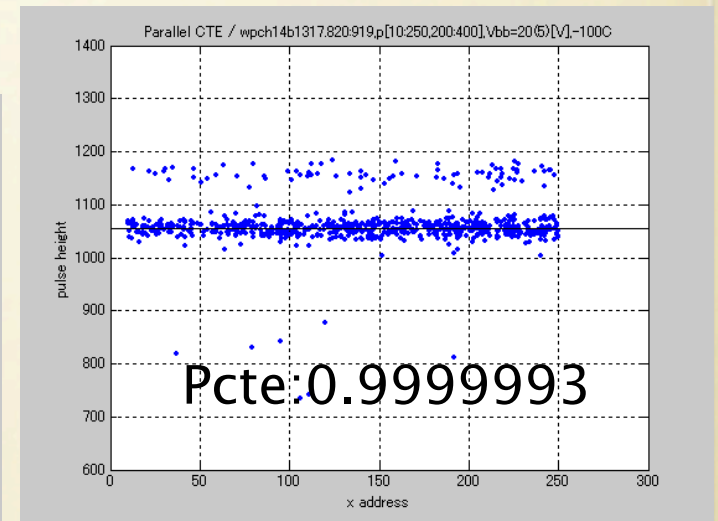
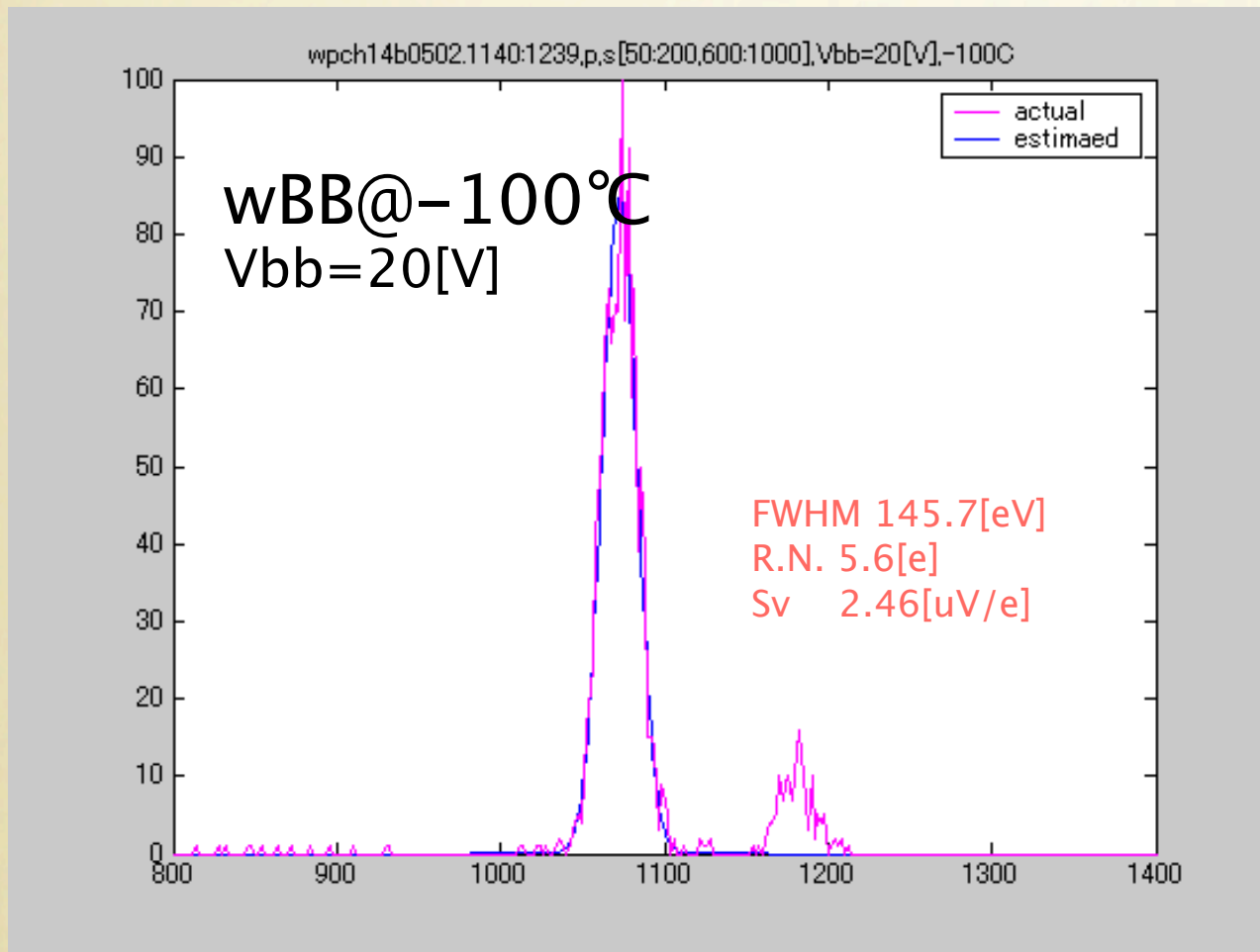

FDCCD CHARACTERIZATION

Parallel CTE	0.999995
Serial CTE	0.999995
Quantum Efficiency	40 % (400 nm) 90 % (650 nm) 40 % (10000 nm)
Thickness	≥ 150 [μm]
Dark Current	1.4 [e/hour/pixel]
Full Well	180,000 [e]
Amplifier Responsivity	5.8 [$\mu\text{V}/\text{e}$]
Read Noise	4.4 e at 150 kHz readout

$$T_{\text{CCD}} = -100^{\circ}\text{C}$$

Sc CCD REPLACEMENT

- 2007 MIT/LL CCIDs of Suprime-Cam will be replaced



New Dewar for
HPK FDCCD

FDCCD FOR HSC

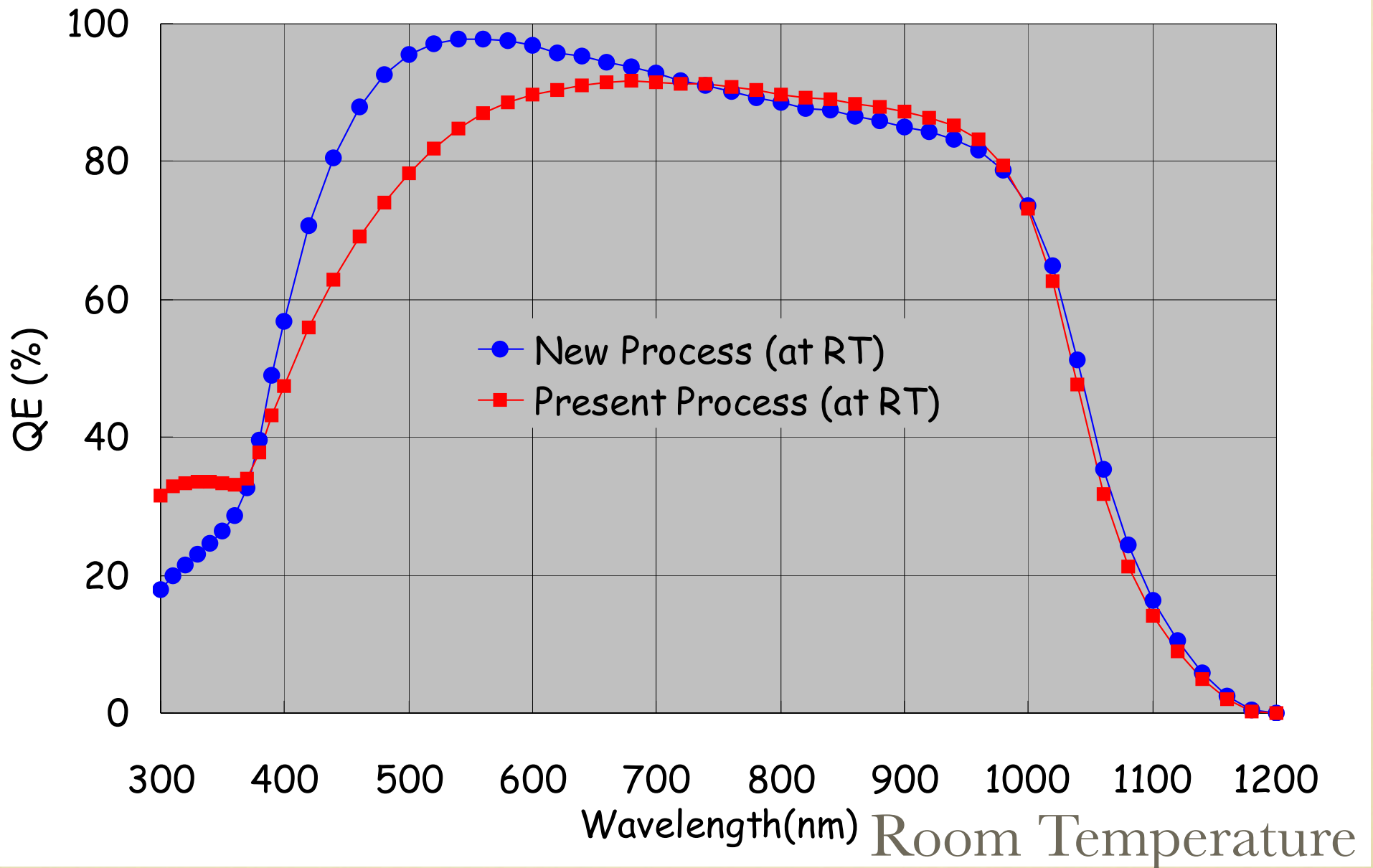

HSC SCHEDULE

PDR

FDR

FL



Assembly and Test

Optics

Design

Manufacturing

Canon

CCD Manufacturing

HAMAMATSU Japan

HSC
Mechanics

Concept

Design

Manufacturing

MITSUBISHI
Changes for the Better

Camera
Mechanics

Concept

Design

Manufacturing



COMPARISON

Project	$A\Omega$	F.L.	Obs. Time	Survey (deg ²)
DES	37	2009	\triangle	5000
Pan-STARRS	13.4×4	2007 PS1	\circ	1200, 31000
HSC	91	2011	\times	2000
LSST	329	2013~2014	\circ	20000
DUNE	0.57	-	\circ	20000
SNAP	1.1	-	\circ	1000, 10000

HSC Pros

Demonstrated High Img Qlty
High Performance CCD

HSC Cons

Difficulty in obtaining
telescope time

MESSAGE TO WFMOS DESIGN TEAM

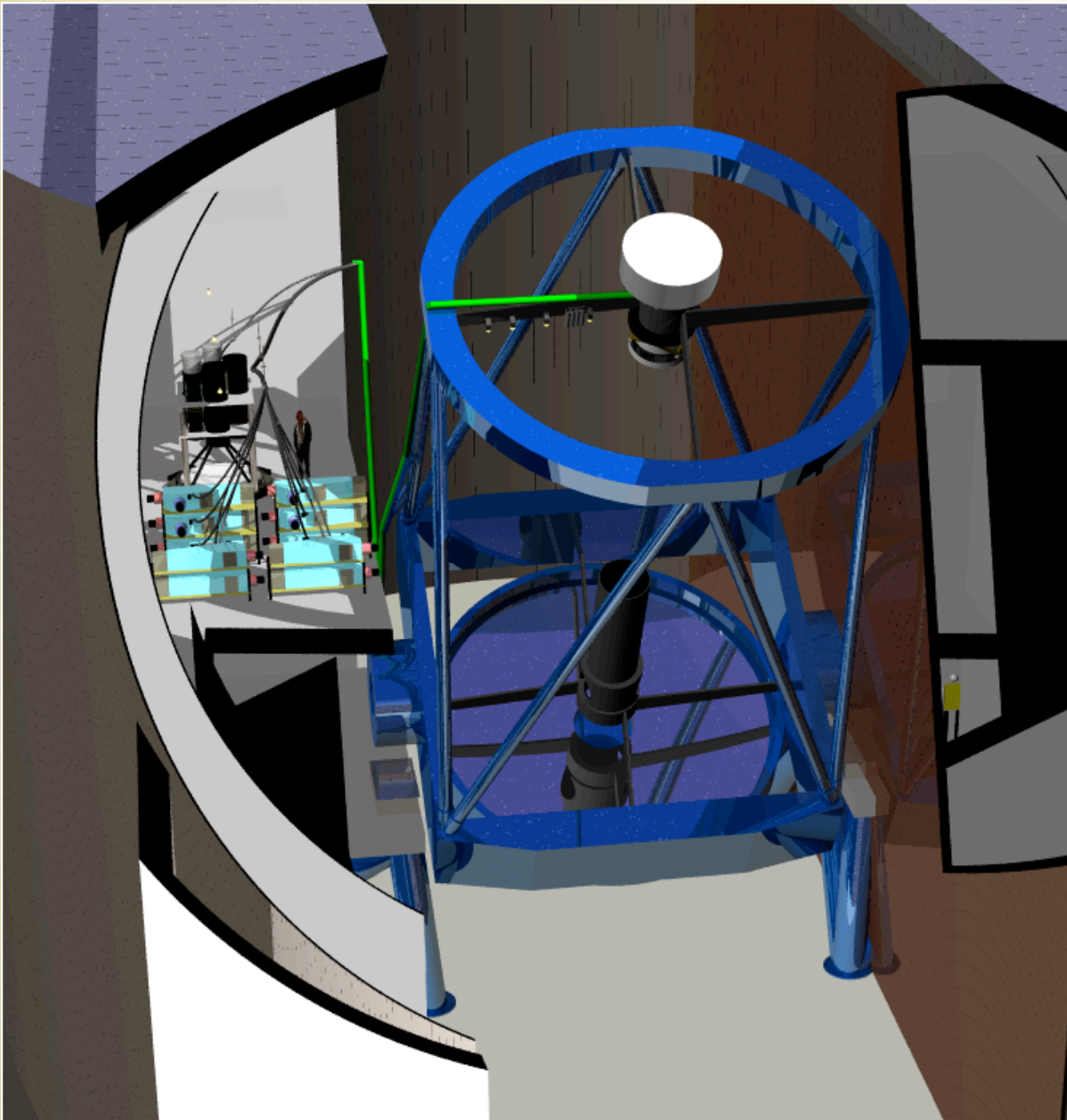

Happy to work with you

Space constraint is tighter than originally expected.

Some compromises of specs. will be inevitable. (eg vignetting)

More flexible and frequent communication is crucial at this stage.

SUMMARY

- HSC $\sim 10 \times$ SC with red QE enhancement
 - Competitive with others but not outstanding
- Telescope time is hard to obtain:
 - Pursuing single science case (eg DE) is not the only option.
- Good Astronomical Survey have to be designed
 - Princeton collaboration
- WFMOS extension is unique and interesting.

Thank You